

BEE CODE

DRYERS

Prepared for

Bureau of Energy Efficiency,
(under Ministry of Power, Government of
India)
Hall no.4, 2nd Floor,
NBCC Tower,
Bhikaji Cama Place,
New Delhi – 110066.

**Indian Renewable Energy Development
Agency,**

Core 4A, East Court,
1st Floor, India Habitat Centre,
Lodhi Road,
New Delhi – 110003.

By

Devki Energy Consultancy Pvt. Ltd.,
405, Ivory Terrace,
R.C. Dutt Road,
Vadodara – 390007.

2006

CONTENTS

LIST OF FIGURES	3
LIST OF TABLES	3
1. OBJECTIVE AND SCOPE	4
1. OBJECTIVE AND SCOPE	4
1.1 OBJECTIVE	4
1.2 SCOPE	4
2 DEFINITIONS AND DESCRIPTIONS OF TERMS	6
2.1 DESCRIPTION OF TERMS	6
2.2 SYMBOLS & UNITS	9
3 GUIDING PRINCIPLES	12
3.1 BACKGROUND	12
3.2 PLANNING THE TEST & PRECAUTIONS	12
3.3 PRE- TEST REQUIREMENTS	13
4 INSTRUMENTS AND METHODS OF MEASUREMENTS	14
4.1 INPUT AND OUTPUT MATERIAL PROPERTIES	14
4.2 FLUID FLOW MEASUREMENTS	15
4.3 THERMAL ENERGY INPUTS	15
4.4 ELECTRICAL ENERGY INPUTS	17
4.5 TEMPERATURE MEASUREMENTS	17
4.6 PRESSURE MEASUREMENTS	18
4.7 HUMIDITY MEASUREMENTS	18
4.8 AIRFLOW MEASUREMENTS	18
4.9 RECOMMENDED ACCURACIES FOR MEASURING INSTRUMENTS	20
5 COMPUTATION OF RESULTS	21
5.1 MEASUREMENTS & CALCULATIONS	21
6 FORMAT OF TEST RESULTS	23
6.1 GENERAL INFORMATION FORMAT	23
6.2 FORMAT OF MEASUREMENTS & TEST RESULTS	24
7 UNCERTAINTY ANALYSIS	26
7.1 INTRODUCTION	26
7.2 METHODOLOGY	26
7.3 UNCERTAINTY EVALUATION OF DRYER EFFICIENCY TESTING:	28
8 GUIDE TO IDENTIFYING ENERGY SAVING OPPORTUNITIES	31
8.1 BACKGROUND	31
8.2 DIAGNOSTICS	32
8.3 ENERGY CONSERVATION OPPORTUNITES	33
ANNEXURE-1: HEAT AND MASS BALANCE CALCULATIONS OF DRYER	35
ANNEXURE 2: SI UNITS, CONVERSION FACTORS & PREFIXES	41
ANNEXURE 3: REFERENCES	43

List of figures

Figure 4-1: Air flow for rectangular ducts 19
Figure 4-2: Air flow for circular ducts..... 20
Figure 8-1: Drying curve 31
Figure 8-2: drying curve for spray drying of food..... 31
Figure A1-1: Flow diagram..... 39
Figure A1-2: Sankey diagram for energy flow..... 40

List of Tables

Table 4-1: Types of paper..... 14
Table 4-2: Measurement points location..... 19
Table 4-3: Summary of instrument accuracies..... 20
Table 5-5-1: Format for Dryer Efficiency Estimation 22
Table 7-1: Uncertainty evaluation sheet-1..... 27
Table 7-2: Uncertainty evaluation sheet-2..... 27
Table 7-3: Uncertainty evaluation sheet-3..... 27
Table 7-4: Uncertainty analysis for Dryer efficiency Testing 28
Table 8-1: Expected Dryer Efficiencies..... 33
Table A1-0-1: Measurements..... 37
Table A1-2: Dryer heat balance 40

1. OBJECTIVE AND SCOPE

1.1 Objective

The purpose of this BEE code is to establish rules and guidelines for conducting tests on dryers at site conditions. This code is simplified as far as possible to reduce the measurements to the minimum necessary with easily usable instruments/equipments under site conditions.

An easily understood term for energy performance of a dryer is Specific Energy Consumption, which is a ratio of energy consumed per kg of water evaporated. Usually weightage is given to the thermal form of energy only and the ratios denoting energy performance are:

- i. SSC (Specific Steam Consumption), kg steam /kg evaporation
- ii. SHC (Specific Heat Consumption), kJ/kg evaporation
- iii. SFC (Specific Fuel Consumption), kg fuel/kg evaporation
- iv. TE (Thermal Efficiency),

The objective of this code is primarily to estimate the above named thermal performance indices. Calculations are presented in this code for further evolving energy balance of dryers to provide a basis for estimating energy saving potential.

1.2 Scope

The term 'Drying' involves removal of water or volatile solvent from a solid (generally the former) by thermal energy. The code does not cover evaporators which produce liquid/suspension/slurry with higher concentration. The output of a dryer is generally dry solids.

The code deals with major and most common type of industrial dryers which belong to two major categories.

- a) Hot air dryers/direct dryers/convective dryers, in which hot air heated by various methods directly comes in contact with drying materials. Rotary Dryers, Fluidised Bed Dryers, Tray Dryers and Spray Dryers are common types. Used in Pharmaceutical, Dairy, Food & Chemical industries.
- b) Contact dryers/indirect dryers/conductive dryers, in which material is heated in contact with the hot wall of the drying cylinder, tray, rotor body etc. This principle is commonly found in paper and textile dryers, rotary dryers etc.

The code does not cover special dryers like Infra-red, Dielectric, Freeze Dryers, Absorption, & Adsorption Dryers etc.

1.2.1 Reference Standards

The following standards/codes are referred for preparing this code.

1. AICHE (American Institute of Chemical Engineers) – Equipment Testing procedure: 1988: Spray Dryers- A guide to performance evaluation
2. AICHE (American Institute of Chemical Engineers) – Equipment Testing procedure: 1968: Rotary Continuous Direct Heat Dryers
3. ASTM-D 644-99: Standard test method for Moisture Content in Paper and Paper board by Oven Drying

4. IS : 6637-1972: Method for determination of Moisture in Wool
5. IS : 5436-1969: Method of testing oil fired rotary dryers for hot mix asphalt
6. IS : 11620-1986: Code of Practice for Fluidised Bed Dryers
7. IS :13859- 1993: Instant Tea in solid form -Determination of moisture content
8. IS: 199-1989: Textiles- Estimation of Moisture

In laying down the procedural guidelines for the dryer energy efficiency evaluation, AICHE references given above provided a useful framework. Moisture determination procedures necessarily differ with nature of materials; IS and ASTM codes explains methodologies for moisture content estimation in most of the materials.

2 DEFINITIONS AND DESCRIPTIONS OF TERMS

2.1 Description of terms

Drying is an operation in which a volatile liquid, usually water, is separated from a solid or semi solid material by evaporation.

Drying involves supplying heat to the wet material being dried (heat transfer) and removing volatiles/water from it (mass transfer) and therefore accounting for incoming and outgoing materials (material balance) and incoming and outgoing thermal energy (heat balance) is useful in studying dryer performance in terms of evaporation and thermal energy inputs. Following is the terminology commonly used for describing drying operations.

2.1.1 Terms related to drying materials

- Feed: Wet input material to the dryer is termed as feed.
- Fines: These are small diameter particles in the feed itself or those which are formed during handling and drying from the larger particles (The fines may be carried by the gas stream used for drying and may need use of separators after drying)
- Hygroscopic /non hygroscopic materials: material that has ability to absorb and bind moisture by hygroscopic forces (depending on nature of the product and temperature/humidity of the surroundings is termed as hygroscopic. Material, which does not contain any bound moisture, is called non-hygroscopic.

2.1.2 Terms related to level/nature of moisture in drying materials

- Bone Dry Material: Any material, which has been dried at sufficiently high temperature for a prolonged time by well-established methods till it is devoid of all traces of moisture, is called 'Bone Dry Material'.
- Moisture Content: The loss of moisture under standard prescribed drying condition till bone-dry state is reached is termed as the 'moisture content' of the material and is usually expressed as a fraction of moisture per kg of wet material (wet basis) or expressed as fraction of moisture per kg of bone-dry material (bone dry basis). Moisture refers to water, although other liquids may follow the same testing techniques.
- Moisture Gradient: In the bulk of material like in a thick bed or in the tray dryer, moisture may not be uniformly distributed in all portions of the solid at a given moment during the process of drying. The actual distribution/content of the moisture in the solid is termed as moisture gradient.
- Bound Moisture: Liquid bound in the solid in its capillaries, by solution in its cells/walls, by solution and by chemical/physical adsorption. It is to be noted that this bound moisture exerts less vapour pressure (i.e. the drying force for evaporation) than that of pure liquid in free condition at the same temperature.
- Equilibrium moisture content: It is the level of bound moisture in a given material which is attained on stabilization under specified conditions of temperature and humidity either by losing excess moisture by drying or by absorbing moisture from surroundings.

- Free moisture: In a hygroscopic material, it is the moisture in excess of the equilibrium moisture content at existing humidity and temperature and includes unbound as well as bound moisture which can be removed.
- Critical moisture: Is the level of moisture content of a material when the rate of drying changes from a constant level to a gradually reducing level.

2.1.3 Terms related to drying process

- Periods of Drying: As drying proceeds, moisture content and rate of drying change with respect to time as follows.

Initially the moisture evaporates from the saturated surface of a solid. In this phase, the rate of drying per unit drying area is CONSTANT. At the end of this, there is a decrease in the area of saturated surface and a transition level called CRITICAL MOISTURE CONTENT is reached. Finally, the water diffuses from the interior and then evaporates. In this phase called FALLING RATE PERIOD of drying, the instantaneous rate of drying continuously decreases, in falling rate period.

During the process of drying after the superficial moisture is evaporated there comes a state when outside air starts getting sucked in to the pores by capillary action. Later as drying proceeds further, capillary action also cannot occur because a continuous film of liquid no longer exists between and around the discrete particles.

The DRYING CURVE is a graphical representation of moisture content of the product vs. time during the process of drying and it identifies the constant, critical and falling rate regimes of drying.

The DRYING RATE is measured as moisture lost in unit time and DRYING TIME is the time taken for reducing the moisture in the product from higher to lower level. RESIDENCE TIME is the time taken by the product to travel from the feed end to the discharge end.

2.1.4 Terms Related to Heat and Mass Transfer/Psychrometric Processes.

- Absolute Humidity: It is the amount of liquid(eg. water) vapour in a given gas stream expressed as weight of liquid per weight of dry gas, expressed as kg of liquid /kg of dry air
- Relative Humidity: It is the ratio of the partial pressure of the condensable vapour in the gas to the vapour pressure of the pure vapour at the same temperature expressed as a percentage.
- Wet Bulb Temperature: It is the dynamic equilibrium temperature attained by a liquid surface when the rate of heat transfer to the surface by convection equals the rate of mass transfer away from the surface.
- Dew Point: Is the saturation temperature at which the mixture of liquid (e.g. water) vapour and the air is saturated – the relative humidity is then 100%. At that temperature the liquid exerts a pressure from inside which is equal to the partial pressure of the vapour of that liquid in its air-vapour mixture.
- Sensible heat: It is the energy involved in changing the temperature of a given substance.
- Latent heat: It is the energy involved in a phase change (e.g. liquid to vapour) which does not result in a temperature change, expressed as kJ/kg.

- Humid Heat: Is the heat necessary to cause a unit temperature increase in a unit mass of humid air (dry air + moisture)
- Material Balance: It is an account of material entering a system, which must equal the material leaving a system if no hold up occurs. Care must be taken to account for the various means through which material can leave a system. For example, in a spray dryer, dried powder can come out through the main dryer as well as through the dust collector.
- Heat Balance: It is an account of the heat supplied to the system and the heat used. The heat required in the dryer is generally made up of the following:
 - Sensible heat to for raising the material to the drying temperature.
 - Heat required for raising the temperature and then the evaporation of the liquid
 - Heat losses through the equipment losing by radiation and convection.
 - Heat lost in exhaust or due to air leakage and in the rejected heating medium like condensate if it is not recovered/recycled.

It is to be noted that electrical energy is utilized in a dryer for (i) transport of material (ii) performing of material (iii) filtration of the material (iv) for creating gas/air flows for circulation in the dryer and for exhaust and (v) for size reduction or aggregation of the material, etc. It is desirable to record these but do not form part of the heat balance.

- Thermal Efficiency: It is the percentage of total energy supply which is used to evaporate water (or solvent).

The letter symbols in the code may be used with appropriate subscript, which may designate a place in space or time a system of units or a constant or reference value. The terminology refers principally to the unit operation of drying to remove water, though often drying of other solvents is also involved.

The definitions conform generally to common usage but as there are many types of dryers and many modes of dryer operation there are exceptions to some definitions.

2.1.5 Equipments

- Dryer: It is an assembly of equipments used for removal of moisture from solids by evaporation.
- Continuous Dryers: These are those in which the feed, moisture evaporations are continuous and uniform
- Batch Dryers: These are those in which either the feed operation or discharge operation or both are intermittent.
- Direct Dryers: Heat is transferred from hot gases by direct contact with wet solids. The vaporized liquid is carried away by hot gases. These are hot-air/convection dryers.
- Indirect Dryers: Heat is transferred to the wet solid through a retaining wall. The rate of drying depends on good contact of wet materials with hot surfaces. These are conduction/contact dryers.

2.2 Symbols & Units

A listing of major symbols with appropriate subscripts and units of measurements in SI system is given below with a view to cover a large variety of dryer types. Some useful conversion factors are provided in Annexure-2.

2.2.1 Feed Material (w)

w_{in} Bone-dry solid material input to a dryer, kg/s.

w_{dust} Bone dry solid material from the dust collector, kg/s.

w_{out} Bone dry solid material output from dryer proper, kg/s.

Note: For batch processes the values will be in kg. Alternatively, if rates are measured, multiply rate with operating hours/batch to get actual quantity used in batches.

2.2.2 Moisture/solvent in Material (m)

m_{in} : Moisture in feed, kg/kg bone dry material.

m_{dust} : Moisture in dust collector material output, kg/kg bone dry material

m_{out} : Moisture in dried product output of dryer proper, kg/kg bone dry material.

2.2.3 Quantity of Heating Fluid (Q)

Q_f : Quantity of circulating heating fluid into and out of heaters, kg/s.

Q_{con} : Quantity of condensate, kg/s

2.2.4 Air Flow Rates (volumes) (V)

V_{in} : Inlet air flow to dryer, m^3/s

V_{out} : Exhaust air flow from dryer proper, m^3/s

V_{comb} : Volume of air for combustion of fuel, m^3/s

V_{add} : Volume of additional out side air fed in heated air, m^3/s

V_{dust} : Volume of air exhausted from dust collector or otherwise, m^3/s

2.2.5 Mass Flow Rates and Humid volumes of air.(G and h_v)

Mass flow rates are denoted by G_{in} , G_{out} , G_{comb} , G_{add} , G_{dust} , etc. for the above and are expressed in kg/s.

Leakage air is G_{leak} .

Gain in weight of air due to evaporation is G_{evpn} .

Humid volumes corresponding to above mentioned volume flow rates are denoted by h_{v-in} , h_{v-out} , h_{v-comb} , h_{v-add} and h_{v-dust} , etc. and are expressed in, m^3 of air-water mixture/kg dry gas.

2.2.6 Absolute humidity of Air (h)

h_{in} Humidity of dryer inlet gas, kg/kg of dry air

h_{out} Humidity of dryer outlet gas, kg/kg of dry air

h_{amb} Humidity of ambient air, kg/kg of dry air

2.2.7 Temperatures of Air (T)

T_{in} : Dryer inlet gas air temperature, °C
 T_{out} : Dryer outlet gas air temperature, °C
 T_{amb} : Ambient air temperature, °C
 T_{dust} : Air outlet temperature at dust collector, °C
 T_{wb} : Wet bulb temperature of air, °C (at specified location)
 T_{db} : Dry bulb temperature of air, °C (at specified location)

2.2.8 Temperatures of steam/Thermic fluid/condensate (T)

T_{st} : Steam temperature, °C
 T_{con} : Temperature of condensate, °C
 T_{tf} : Temperature of thermic fluid, °C.

2.2.9 Temperature of solid/materials. (T_s)

T_{s-in} : Inlet temperature of solids (at dryer), °C
 T_{s-out} : Outlet temperature of solids (at dryer), °C
 T_{s-dust} : Temperature of solids from dust collector, °C

2.2.10 Specific heat, Sensible heat & Latent heats (C, h_s & L)

C_{p-s} : Specific heat of solid material being dried, kJ/kg °C
 C_{p-L} : Specific heat of liquid being heated, kJ/kg-°C
 C_{p-v} : Specific heat of vapors evolved on drying, kJ/kg-°C
 C_{p-TF} : Specific heat of Thermic Fluid, kJ/kg-°C
 C_{h-in} : Humid heat of air fed to the dryer
 h_s : Sensible heat in steam, kJ/kg
 L_e : Latent heat of evaporation, kJ/kg
 L_s : Latent heat of steam, kJ/kg

2.2.11 Heat Outputs (H)

H_s : Heat given to solids being dried (inlet to product temperature), kJ/s
 H_{lh} : Heat for sensible heat supply to the liquid in solids (inlet to evaporating temperature), kJ/s
 H_{lv} : Heat for vaporization of liquid at evaporating temperature, kJ/s
 H_{md} : Heat for out going moisture in the dried product (from evaporating temperature to product outlet temperature), kJ/s
 H_{esup} : Heat for superheating of evaporated vapours (from evaporating temperature to product temperature), kJ/s
 H_{rc} : Heat for reaction and crystallization of solids, kJ/s
 H_{sl} : Heat for convective and radiative surface losses of the dryer and related equipments, kJ/s.
 H_h : Heat lost in condensate discharged from the dryer, kJ/s
 H_{tot} : Total heat output as summation of all the above outputs, kJ/s
 H_{ul} : Unaccounted heat losses showing the gap between input and output of heat, kJ/s

Note: For batch processes the values will be in kJ. Averages can be then worked out as kJ/s based on total processing duration in seconds.

2.2.12 Fuel/Heat inputs for Evaporation

H_{in} = Heat input to the dryer, kJ/s
(This assumes various forms like steam/thermic fluid heating to the heaters installed at dryer or heating cold air by combustion products or electrical heating and feeding that air to the dryer as a single input of heat) , and hence

H_{in} = heat required to heat inlet air up to heater outlet temperature before the dryer, kJ/s
= Heat released by steam condensing in dryer heaters, kJ/s
= heat released by electrical heaters, kJ/s
= heat released by cooling of a fixed or variable but known quantity of thermic fluid, kJ/s

2.2.13 Energy Consumption

FC = Fuel consumption, kg/s.

SC = Steam consumption, kg/s.

EC = Electricity consumption, kW

FHV = Heating value of fuel, KJ/kg fuel

C_{eff} = Thermal efficiency of combustion system (boiler/thermic fluid heater/furnace), expressed as a fraction of heat output to heat input where often heat output = heat input – losses of combustion system.

The losses of combustion being established by standard methods of deciding combustion system efficiency by the “loss method”.

For any of the above parameters theoretical/estimated values can be expressed by adding suffix **e**, for example F_{ce} , S_{ce} etc.

3 GUIDING PRINCIPLES

3.1 Background

The method explained in this code is suitable for continuous and batch type dryers falling under the scope of this code. Contact type (indirect heating) dryers like tray dryers, cylinder dryers, some of the rotary dryers, agitated bath dryers or convective dryers with multiple uncontrolled fresh air inlets and multiple exhausts as well as all other types of dryers can be evaluated by using this method.

In this method, measurement of moisture content in material is done before and after the dryer to estimate total moisture removal from the substance. The energy required to drive out this moisture is termed as useful energy spent in the dryer. By measuring the total input heat energy to the dryer, the dryer efficiency is estimated. Details of calculations are given in section 5.1.

Dryer efficiency = [Heat for sensible heat supply to the liquid in solids (inlet to evaporating temperature) + Heat for vaporization of liquid at evaporating temperature + Heat for superheating of evaporated vapour (from evaporating temperature to product temperature)] / [Heat input to the dryer]

To estimate various losses and energy flows in a dryer to obtain a heat balance, a detailed heat balance method is suggested as given in Annexure-1.

3.2 Planning the Test & Precautions

- Safety and environmental requirements must be considered in planning the test. Testing must conform to the latest requirements of all applicable safety and environmental standards and procedures, which include plant, industry, local, state and union regulations. Environmental standards that apply to the equipment and process during normal operation must also be achieved to during all test runs.
- All performance testing must be conducted under the supervision of personnel fully experienced in plant and equipment operating practices.
- During test planning, a thorough safety hazards review must be completed of the test program and procedures. All necessary steps must be carried out to ensure safe equipment operation and the safety of all personnel involved or potentially exposed to the test care and study must especially be given to tests and equipments involving flammable vapors and /or flammable or explosive dust
- The representative average moisture content of material is to be determined before and after the dryer. The determination of moisture in the material must be representative of the various sections of ingoing material and various sections of outgoing material. Also it is presumed that the ingoing and outgoing material will have fairly constant moisture throughout the trial period.
- In many cases, there is a possibility of ingress of atmospheric moisture in dried material or of atmospheric evaporation from the wet/dried material before laboratory determination. An appropriate covering of sample by plastic sheet or putting the sample in a closed container is therefore very important.

- If the moisture content in the sample is large or if the bulk of the sample is more in weight less accuracy of weighing can be tolerated. However, for a small sample with very low moisture content the accuracy of weighing must be high. The accuracy of weighing must be such that even 0.1 % moisture on bone dry base should be possible to weigh. For greater accuracy of weighing the sample container must be of thin and light weight material, possibly of sealable type.
- The material to be dried is in a large variety of forms ranging from sheets and large solids to powders, granules, crystals, pastes and sludge or slurries and solids in liquid suspension. Great care is required in handling these for moisture samples like (i) Not holding small moist samples or pasty/sticky samples with hand (ii) In adopting methods of gradual evaporation in the laboratory using slowly heated sand-baths (avoiding direct flame heating) so that vapours and solids do not fly off from the sample.
- For batch operation, the energy efficiency test trial should cover the entire duration of a batch as drying rates and energy inputs vary over the batch processing time. For continuous stabilized dryers, the trial can be reduced to few hours. Repeat runs are desirable to establish trends.

3.3 Pre- Test Requirements

- All data should be labeled with time. If data is collected by two or three investigators, for time measurement, their watches must be synchronized.
- Suitable sampling devices to obtain and retain samples of material at proper locations throughout the drying cycle for subsequent analysis.
- Suitable sampling locations arranged to handle the sampling device adequately so as to obtain uniform samples at desired conditions.
- Stabilised and continuing operations of a batch drying equipment so that total heating of the equipment from cold condition is not called for.
- In continuous type of dryers the studies must be conducted under stabilized conditions of equilibrium.
- Continuous and steady flow of any one category of material should be arranged so that moisture content at inlet and outlet, feed quantity and composition of feed remains constant during trial.
- It should be ensured that all thermal energy inputs like steam/drying gas are arranged for stable/preplanned control with respect to flow and temperature. Any deviations must be noted.
- Any gross abnormality which may affect the test or cause damage during the test run must be avoided. However, since the purpose of the audit is to, evaluate energy efficiency 'in operation' no change may be attempted for improvement prior to trial. All instrumentation needed must be in proper working order.

4 INSTRUMENTS AND METHODS OF MEASUREMENTS

4.1 Input and Output Material properties

The material to be dried in a dryer is in liquid, semi-liquid or solid state. Sometimes it is also in sheet form. Depending upon the material different methods are employed to measure the production input and output such as length/area of the product (knowing its dry g/m^2) volume of the product (knowing its dry kg/m^3) or directly the weight of the product or the volumetric/mass flow rate of the product.

4.1.1 Oven Drying to Estimate Moisture Content in Materials

Weighing in Laboratory : If samples are in kilograms the balance must have measuring accuracy upto 1 gm and if samples are in gms the balance must have measuring accuracy up to 1 mg.

Moisture Removal from Liquid Sample: If sample is liquid or semi liquid, it must be very gradually dried till it can be transferred to a ventilated oven with thermostat to control the temperature.

4.1.2 Length and Area of the Product (Textiles/Paper)

This method is used in case of sheet materials like paper and fabrics. The production is generally measured in terms of linear speed of the machine in m/minute. The weight of fabric is known as g/m^2 or kg/m^2 and varies from 0.05 to 0.2 kg/m^2 or more depending on the fabric variety and as determined on bone dry basis. In paper industry, 30 lb – newsprint would mean that the weight of the 500 sheets of paper in a ream having a size of 24 x 36 in is 30 lbs. It should be borne in mind that in drying of paper sheets problems of bulges, wrinkles or shrinkage arise and can influence uniform drying. The sheet paper is known to shrink in width to varying degrees in the range of 2 to 8% but on an average by 3 to 5%. The heavier the paper and slower the stock, the greater is the shrinkage. The basis weight of some varieties is given below.

Table 4-1: Types of paper

Type	Sheets	g/m^2	Weight, kg
Writing grade (17" X 22")	500	60.1	7.264
		75	9.080
		90.2	10.896
		105.2	12.712
		120.3	14.528
		139	16.800
News paper (24" X 36")	500	52.1	14.528
Kraft bag (24" X 36")	500	48.8	13.62
Kraft wrapping & gray fibre (24" X 36")	500	81.3	22.7

For example, 500 sheets of 17" X 22" have a basis weight of 7.264 kg or 16 lbs. The common basis weight used in paper industry are 16,20,24,28,30,32,50 etc.

4.1.3 Volume of the Product/Weighing on Conveyor:

If the bulk density of the wet or dry product is known and if the product is emptied from hoppers or collected into bins of known volume, the production rate can be calculated. This especially can occur in case of free flowing product. However there are often arrangements for direct weighing on the conveyor itself. Those are ideal arrangements if available at site. Refer 4.1.1 for laboratory weighing

4.2 Fluid Flow Measurements

When the substance to be dried is in liquid form many different alternatives are possible as follows :

Tanks : Suitably designed volumetric tanks can be accurate within $\pm 0.5\%$ of total volume. Volumetric tanks should be calibrated prior to a test with weighted incremental additions of liquid measured at a known temperature. Density corrections should be made for the difference in temperature of the liquid measured and the temperature at the time the tank was calibrated.

All liquids being measured in open tanks should be cooled below their boiling point to avoid vapour/flash loss effect.

Any other type of calibrated in-situ flow meters can also be used, such as differential pressure meters, rotameters, weirs, positive displacement flow meters magnetic flow meters, ultrasonic flow meters etc. The error need to be limited to less than 2%.

4.3 Thermal Energy Inputs

4.3.1 Steam Consumption

1. Condensate collection: For batch dryers involving very low steam consumption over long durations, condensate can be collected in drums with liquid level tubes or open tanks. Depending on the average steam pressure at the heater a factor F must be used to the condensate collected due to flash steam loss.

$$F = \frac{(h_{s1} - h_{s2})}{L_{s2}} \times 100$$

Where, F = % of condensate lost as flash steam

h_{s1} and h_{s2} = sensible heat in condensate at the upstream pressures
Respectively, kJ/kg.

L_{s2} = latent heat of steam at the down stream pressure, kJ/kg.

Typically flash steam loss to atmosphere can be about 9.5% at 4 kg/cm².g. and About 13% at 7 kg/cm².g

It should also be checked that the steam used is not superheated and if necessary due allowance must be given for degree of superheat.

Generally steam meters have a built in orifice and turbine and need a pressure correction factor to be applied for deviations from the designed pressure. If the meters are well maintained the error generally is of the order of + 2 to 3%.

4.3.2 Fuel Consumption and Heat Output

Hot gases generated from fuel firing may be used for feeding the dryer. Measurement of hot gases is often difficult without any special provisions being made. The heat input to a dryer can be derived from the quantity of fuel consumption stoichiometry and excess air input for combustion, fuel analysis and GCV/NCV of the fuel and thermal efficiency of combustion. This method would require exclusive working of a combustion equipment for the dryer under test only.

(i) Measuring Fuel Consumption

- (a) Gas Firing : The gas to be fired needs to be metered and due allowance incorporated for pressure variation. The G.C.V. of the gas and its characteristic constituents must be reasonably known.
- (b) Oil Firing : The total quantity of oil used during the test shall be measured to an accuracy of $\pm 2.5\%$ where possible a small service fuel tank mounted on a scale so that it can be weighed/measured accurately by dipping at the beginning and end of a test should be used to find the quantity of oil burned.

Alternatively, the oil level in the main tank should be measured at the beginning and end of the test period. The duration should be such that the change of level is at least 40 mm and the measurement should be made to an accuracy of ± 1 mm. If change of level as indicated is not achieved, a service tank should be fitted.

The oil consumption should be expressed as litres/hour and can be linked to product dried as litres/ton of aggregate dried. The type, calorific value and specific gravity of oil used need to be specified.

- (c) Solid Fuel Firing : The total quantity of solid fuel used (coal, lignite, wood, agro fuel) must be weighed. A representative sample of the fuel about 0.5% of fuel fired being fired must be drawn in small lots over the test period. Similarly ash sample must be drawn and sent for Proximate and Ultimate Analysis and analysis of unburnt in ash

In all of the above tests if combustion gas output is to be known, the efficiency of combustion must be estimated by loss method and the amount of excess air and stoichiometric air must be found from fuel analysis and averaged oxygen content in flue gases. This procedure will entail the thermal efficiency test in addition to the dryer test.

Heat Output to Drier

= fuel Consumption x calorific value of the fuel x thermal efficiency of combustion.

- (d) Hot Gas Flow Measurement :

For accounting by this method, long runs of straight ducts would be required. It is desired that flow in the measurement duct should be uniform. Averaging type of total head and static head devices are ideal. Orifices, Nozzles and Venturi meters can also be used. Some preliminary work is needed to establish such flow measurement. Local velocity devices like vane type/pitot type flow meters can also be used where cold air intakes are arranged for combustion chamber. A proper traverse is required to get true average of the air flow.

4.4 Electrical Energy Inputs

A listing of equipments consuming electrical energy must be made and categorized into

- (a) Preparatory /post drying equipment :

Those would include any Preformer, Pulveriser, Sqveezer, Filter, Cooling Fans, Granulating system, etc.

- (b) Essential parts of dryer :

These would include air inlet fans for generating hot air through a heating system/by directly providing air for combustion, any additional cold air Injection fan or recirculation fans and exhaust fans, any pumps or material recirculatory arrangements or conveyor (band) drive, etc.

Depending upon the nature of dryer, the trial may last for a few hours or many hours. The electrical energy can be measured in above two categories or any other convenient categories by installing energy meters.

Portable power analysers of adequate capacity ratings may be used. For example, for small range of 5 to 20 KW power a 200 KW instrument should not be used.

In many processes the extent of power consumption would be variable and depend on process stage and time elapsed after material was introduced for drying In such cases many instant readings should be taken by portable instrument over the trial duration.

4.5 Temperature Measurements

Depending on the location and actual temperature more than one temperature measuring devices would be needed for measuring temperatures of ambient air, hot gas for drying, product inlet and outlet temperature, exhaust temperature, etc. The following instruments can be used:

- (a) calibrated mercury in glass thermometer
- (b) thermocouple
- (c) resistance thermometer

The temperature device shall be so chosen that it can be read with an accuracy of 1% of the absolute temperature. Absolute value of full scale error shall not exceed 1 deg. C where bulk measurements are involved. Readings from different positions of the bulk must be taken and averaged. For liquids cup-type reservoirs to sample liquid and dip thermometers are useful.

Sometime it is convenient to use non-contact infrared instruments specially when surface temperatures need to be measured to cross check effectiveness of insulation or to estimate radiation and convective heat losses or when owing to local inconvenience bulk temperature can not be easily measured. In using infrared pyrometers proper range and emissivity must be selected and the spot of temperature measurement must be targeted. Measuring temperature from long distances should be avoided as such instruments cover a much larger viewing field when distance is more.

Contact thermocouples with flat probes can also be used for surface temperature measurements.

4.6 Pressure Measurements

The steam pressure or vacuum shall be measured at the steam meter or nearby with an isolating U tube, cock and a bourdon guage. Such pressure or vacuum guage will be calibrated against standard dead weight guage or master guage. The graduations shall permit readings within 1% of the expected pressure/vacuum measurement.

4.7 Humidity Measurements

For finding the moisture contents of air, dry bulb and wet bulb temperature measurements are essential. It is easy to measure humidity of air under ambient conditions by swinging a sling psychrometer with hand. The air/gas whose wet bulb is to be measured must have a velocity of 5 to 8 m/s over the wetted bulb. In the hot air ducts usually such velocities are available. If not, a portion of the gas flow can be directed to the bulb. The usual wet bulb thermometer has a wick dipped in water which is close to wet bulb temperature when the temperature is high and the relative humidity is low the wet bulb is quite low and evaporation from the wick is too rapid. Three possible approaches can be used to determine wet bulb under such conditions.

1. A long stem mercury in glass thermometer of up to 110 deg. C range with 0.5 deg. C graduations can be covered with a absorbent and clean cotton wick and held in the hot humid air stream while watching the temperature rise. The temperature will rise rapidly and stabilise at the wet bulb temperature which should be carefully noted immediately. After this stage the temperature will again start rising when the thermometer must be withdrawn quickly. This direct method is suitable for temperatures up to about 350 deg. K in wet bulb and clean air.
2. A sample of the gas must be diverted from the main stream and cooled but condensation must be avoided. Wet and dry bulb both then should be measured from this sample. Alternatively a gas sample that cleans dusty sample and cools the air to dew point is required. The degree of accuracy for gas wet bulb or dew point temperature measurements is $\pm 0.5\%$ of the absolute gas temperature reading.

4.8 Airflow measurements

Airflow measurements are required only if a heat balance of dryer is being estimated. For direct efficiency testing of dryers, this is not a primary requirement.

The measurement of airflow is required either in the supply air or in the exhaust air. An orifice or venturi meter is often permanently installed in large plants for continuous measurement of air velocity. If suitable duct length exists in the supply air side, venturi is preferred over orifice as it has higher discharge coefficient and is more efficient due to less pressure drop.

For testing purposes, pitot tube/anemometers can be used. Pitot tube is suitable for velocities more than 3 m/s and can be used up to 700 °C. For lower air velocities, anemometer is useful. Both instruments have limitations as follows.

Pitot tube: These can only be used in powder free clean air streams after the cyclone/bag filter. The point of measurement should ideally have six diameters of straight duct length before the measurement point. Also the use of pitot tube should not be attempted at positions closer than one duct diameter to any upstream bend or damper.

The static holes of the pitot must be free from burrs and clean and the tube should not have dents. While measuring, the angle of deviation of the pitot from the air stream must be zero, otherwise with 10° misalignment, the deviation from true reading can be upto 5%.

Anemometer: The anemometer is not suitable for hot powder laden airflow or ducts handling corrosive/explosive air-gas mixtures. Anemometer can have $\pm 1\%$ accuracy.

The pitot tube /anemometer measurements can be conducted to determine velocity profile over the duct as discussed below in section 4.7.1 and average velocity can be calculated. Volume flow is derived from cross sectional area and mass flow is calculated from the humid volume of the air-water mixture.

4.8.1 Log Tchebycheff method for rectangular ducts

Refer figure 4.1. The intersection points of vertical and horizontal line are the points where air flow measurement is required. For width H and height V, the location of points are indicated in the figure. Air flow is obtained by multiplying average velocity measured at all points with area.

Table 4-2: Measurement points location

No. of traverse lines		
5 (for $H < 30''$)	6 (for $36'' > H > 30''$)	7 for $H > 36''$
0.074	0.061	0.053
0.288	0.235	0.203
0.5	0.437	0.366
0.712	0.563	0.5
0.926	0.765	0.634
	0.939	0.797
		0.947

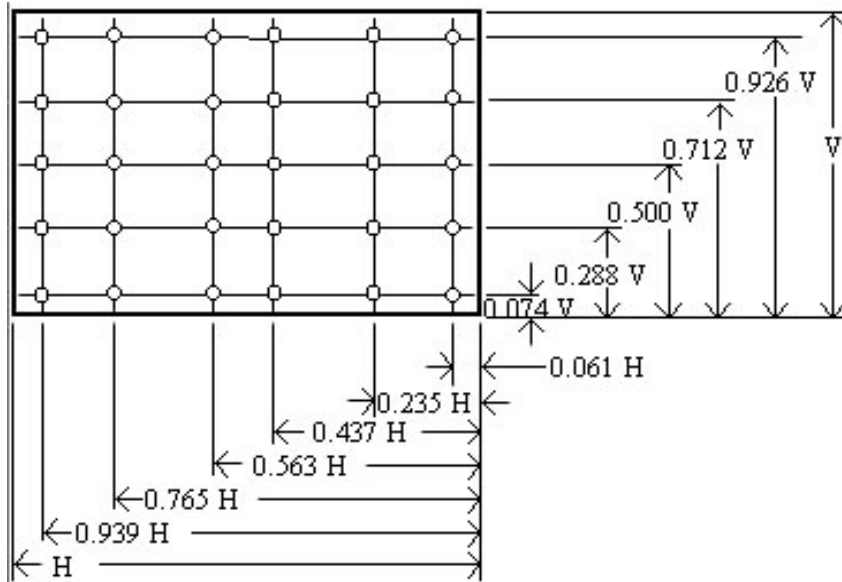

Figure 4-1: Air flow for rectangular ducts

4.8.2 Log Tchebycheff method for circular ducts

The duct is divided into concentric circles, applying multiplying factors to the diameter. An equal number of readings is taken from each circular area, thus obtaining the best average. Air flow is obtained by multiplying average velocity measured at all points with area.

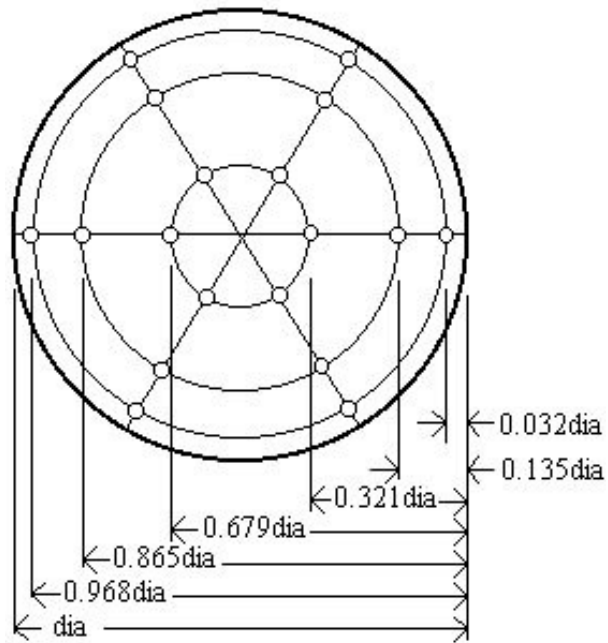

Figure 4-2: Air flow for circular ducts

4.9 Recommended Accuracies for Measuring Instruments

The recommended accuracies for measuring instruments is given below. For calibrating various instruments, visit www.nabl-india.org for a detailed list of accredited laboratories. Calibration interval suggested for instruments is 6 months.

Table 4-3: Summary of instrument accuracies

Instrument and range	Accuracy
Mass, in kg	1 g (0.001 kg)
Mass, in g	1 mg (0.001g)
Fluid Flow, kg/hr or m ³ /hr	2%
Steam flow	3%
Temperature	1%. (Precision of 0.1 C)
Humidity	0.5%
Airflow	1.0%

5 COMPUTATION OF RESULTS

5.1 Measurements & Calculations

Chronological order of measurements and estimations:

1. Comply with the pre- test requirements and precautions
2. Measure moisture content of material at inlet to dryer
3. Measure moisture content of material at outlet of dryer
4. Measure dry bulb and wet bulb temperature of air at dryer inlet and outlet
5. Measure weight of dried material for a batch dryer. Material weight flow rate to be measured for a continuous dryer.
6. Measure input thermal energy to dryer as given in section for (i) hot air input (ii) Steam heating or (iii) electrical heating through various direct measurements or indirectly from quantity of fuel fired and combustion efficiency assessments for direct fuel fired dryers. In extreme special cases, total heat input may need to be estimated with heat balance.

$$\text{Dryer efficiency} = \frac{(H_{lh} + H_{lv} + H_{e \text{ sup}})}{H_{in}}$$

In contact dryers, there is no superheating of vapour and heat required for evaporation is only $H_{lh} + H_{lv}$

$$\text{Where } H_{lh} = W \times m_{in} \times C_{pl} \times (T_{sout} - T_{sin})$$

$$H_{lv} = W \times (m_{in} - m_{out}) \times L_e$$

In hot air dryers, the vapor evaporated in dryer are further superheated to exhaust temperature. In that case,

$$H_{lh} = W \times m_{in} \times C_{pl} \times (T_{out \text{ wb}} - T_{sin})$$

$$H_{lv} = W \times (m_{in} - m_{out}) \times L_e$$

$$H_{e \text{ sup}} = W \times (m_{in} - m_{out}) \times C_{pv} \times (T_{out \text{ tdb}} - T_{out \text{ wb}})$$

For batch dryers, the material and energy flow rate has to be replaced with total material quantity dried and energy consumed in the period.

The above equations given are programmed into MS Excel spread sheet as given in table 5.1 below.

Table 5-5-1: Format for Dryer Efficiency Estimation

	Parameter	Value or Formula in column D	Unit	Value
	A	B	C	D
1				
2	Date			
3	Trial time			
4	Trial duration		hours	
5	Dry solids output, w_{out} , from dryer as product	Measured value	kg/s or kg	
6	Moisture in solids, m_{in} , at inlet /feed	Measured value	kg/kg of bone dry product	
7	Moisture in solids, m_{out} , in final product	Measured value	kg/kg of bone dry product	
8	Temperature of inlet feed, T_{s-in}	Measured value	°C	
9	Temperature of outlet material, T_{s-out}	Measured value	°C	
10	Dryer inlet air dry bulb temperature, $T_{in db}$	Measured value	°C	
11	Dryer inlet air wet bulb temperature, $T_{in wb}$	Measured value	°C	
12	Dryer outlet air dry bulb temperature, $T_{out db}$	Measured value	°C	
13	Dryer outlet air wet bulb temperature, $T_{out wb}$	Measured value	°C	
14	Latent Heat of Evaporated liquid, L_e	From steam tables	kJ/kg	
15	Specific heat of evaporated liquid, C_{pl}	From steam tables	kJ/kg-°C	
16	Specific heat of evaporated vapour, C_{pv}	From steam tables	kJ/kg-°C	
17	Steam Input flow, S_c	Measured value	kg/s or kg per batch	
18	Enthalpy of Steam, h_s	From steam tables	kJ/kg	
19	Condensate collection, C_c (if steam flow is not measured)	Measured value	kg/s or kg per batch	
20	Enthalpy of condensate, h_c	From steam tables	kJ/kg	
21	Heat for sensible heat supply to the liquid in solids (inlet to evaporating temperature) $H_{lh} = W \times m_{in} \times C_{pl} \times (T_{sout} - T_{sin})$	$D5 * D6 * D15 * (D9 - D8)$	kJ/s or kJ/batch	
22	Heat for vaporization of liquid at evaporating temperature, $H_{lv} = W \times (m_{in} - m_{out}) \times L_e$	$D5 * (D6 - D7) * D14$	kJ/s or kJ/batch	
23	Heat for superheating of evaporated vapour (from evaporating temperature to product temperature) $H_{esup} = W \times (m_{in} - m_{out}) \times C_{pv} \times (T_{out db} - T_{out wb})$	$D5 * (D6 - D7) * D16 * (D12 - D13)$	kJ/s or kJ/batch	
24	Heat input, H_{in}	$(D17 \text{ or } D19) \times (D18 - D20)$	kJ/s or kJ per batch	
25	Dryer efficiency, $\eta =$	$\{D5 * (D6 - D7) * [(D9 - D8) + D10]\} * 100 / D24$	%	

6 FORMAT OF TEST RESULTS

6.1 General Information Format

1. Dryer name
2. Dryer make
3. Approx. year of installation
4. Type of Dryer
 - (a) Working type
 - (i) Direct/Indirect (i.e. convection/contact)
 - (i) Batch/continuous
 - (ii) Parallel flow, counter current flow, cross flow with respect to material movement
 - (iii) Whether through circulation of air from material/fluidization with air/air passage through rotor
 - (iv) Loops/festoon type/single pass or multi pass (desk)/single or multi stage drying
 - (b) Operational mode
 - (i) Tray (chamber/truck type/tunnel truck type/ vacuum)
 - (ii) Conveyor (Through circulation /Hot air)
 - (iii) Rotary (other types/louvre type)
 - (i) Pneumatic/Flash (see annexure for sub types)
 - (ii) Spray dryer (cone/cylindrical shape/whether air sweeper jet provided at bottom/nozzle pressure type/disc atomization/pneumatic atomization)
 - (iii) Fluid bed dryer
 - (iv) Contact dryer (Film Drum/ Cans or Cylinders/Pan type with agitator/Atmospheric Pressure or vacuum)
 - (v) Other Types (Infra red heating/freezing cons vacuum sublimation dielectric dryers/gas dryer with absorption/adsorption)
5. Dimensional Details
 - (i) Overall length, height and width or height and diameter in m.
 - (ii) No. of sections/chambers
 - (iii) Dryer volume and shape, m³
 - (iv) Dryer inclination angle (positive/negative with respect to material)
 - (v) Contact Cylinder Dryers
 - Cylinders (No, length and diam in m – of each size
 - Lap/contact angle on cylinder periphery at entry/exit/general as applicable
 - Vertical stacks – No. of cylinders in each stack
 - Horizontal stacks – No. of cylinders/different sections
6. Inner Details
 - (i) Tray Dryers: No. of tray tracks, tray dimensions, distance between tray, no. of trays, tray area
 - (ii) Conveyor type – wire mesh/apron/ openings no. dimensions for through drying, apron details
 - (iii) Rotary- lifting flight details, total no, flights/m. length of dryer, depth of flight, ratio of flight depth to rotor dia, nature of flight- radial 45 deg lip, 90 deg lip, variation in lip across dryer length
 - (iv) Flash dryer dimensional and other details of drying duct and its length, expansion chambers, venturi, pneumatic classifier
 - (v) Fluid bed dryers – distribution plate details – type, opening area/free board height
 - (vi) Spray dryer
 - type of atomizer

- flow arrangements

7. Information on Auxiliaries

- (i) Material feeding arrangements – press/inclined chute/rotary valve/ vibratory feeder/ rotating table/filters/belt/chain conveyor/counter balanced flap chute in chute for sealing/ screw conveyor/ preformer/disintegrator/centrifuge extruder/pulveriser/any inlet cooling with water
- (j) Material discharge arrangements – any water cooling at outlet/sieve/grinder/cyclones – their nos, volumes/pressure drops/wet scrubber
- (iii) Any dried material recycling and back mixer

8. Nominal dryer output, (kg/s/kg/h/kg/day)

- (i) Wet product
- (ii) Dried product
- (iii) Bone dry product

9. Types of material generally dried and the relevant characteristic details like actual and true bulk densities, solvent properties and related safety and hazard issues, solvent recycling provisions, etc.

10. Energy Inputs

- (i) Medium and arrangements for heat inputs to dryer and related capacity ratings as related to the dryer – steam/hot air generation – flows and pressure/ temperatures – fuel consumption
- (ii) Electricity Consumers, (Ratings and other details)
 - Main electrical heater, kw
 - Combustion air supply fan installed kw, capacity, (m³/h), total pressure, (mmWG)
 - Air recirculation fans (nos, kW, capacity (m³/h) and total pressure (mmWG)
 - Additional/air inlet fan and exhaust fan (nos, kW capacity, pressures as above)
 - Motive Drives, kW (Type – DC, AC, VFD)
 - conveyor
 - Rotor cylinder
 - Pump
 - Atomiser
 - Material feeder

11. Energy Cost

- Fuel cost, Rs./Tonne
- Electricity cost, Rs/kWh

12. Details of measuring instrumentation & controls provided on the machine

6.2 Format Of Measurements & Test Results

The measurements and calculations for testing dryers is given below. Necessary modifications to input heat energy calculations may be done if sources like electricity, hot air, flue gases etc are used.

Name of Industry:

Test Date:

Time:

Details of instruments used

Sl.No	Description	Measured parameter	Description of accuracy
1	Chemical balance	% moisture content in feed and output	
2	Thermometer	Temperature	
3	Anemometer	Measurement of air flow at air heater	

General Information

General Information	
Type of dryer	
Information on Auxiliaries	
Material feeding	
Material discharge	
Nominal bone dry dryer output , kg/hr	
Type of material generally dried	
Energy Inputs	

Measurements and results

Measurements and results			
1	Dry solids output, w_{out} , from dryer as product	kg/h	
2	Moisture in solids, m_{in} , at inlet /feed	kg/kg of bone dry product	
3	Moisture in solids, m_{out} , in final product	kg/kg of bone dry product	
4	Heat for sensible heat supply to the liquid in solids (inlet to evaporating temperature)	kJ/h of KJ/batch	
5	Heat for vaporization of liquid at evaporating temperature	kJ/h of KJ/batch	
6	Heat for superheating of evaporated vapour (from evaporating temperature to product temperature)	kJ/h of KJ/batch	
7	Heat input	kcal/batch or kcal/h	
8	Dryer efficiency	%	
9	Uncertainty	%	

Test conducted by:
(Energy Auditing Firm)

Test witnessed by:
(Energy Manager)

7 UNCERTAINTY ANALYSIS

7.1 Introduction

Uncertainty denotes the range of error, i.e. the region in which one guesses the error to be. The purpose of uncertainty analysis is to use information in order to quantify the amount of confidence in the result. The uncertainty analysis tells us how confident one should be in the results obtained from a test.

Guide to the Expression of Uncertainty in Measurement (or GUM as it is now often called) was published in 1993 (corrected and reprinted in 1995) by ISO. The focus of the ISO *Guide* or GUM is the establishment of "general rules for evaluating and expressing uncertainty in measurement that can be followed at various levels of accuracy".

The following methodology is a simplified version of estimating combined uncertainty at field conditions, based on GUM.

7.2 Methodology

Uncertainty is expressed as $X \pm y$ where X is the calculated result and y is the estimated standard deviation. As instrument accuracies are increased, y decreases thus increasing the confidence in the results.

A calculated result, r , which is a function of measured variables $X_1, X_2, X_3, \dots, X_n$ can be expressed as follows:

$$r = f(X_1, X_2, X_3, \dots, X_n)$$

The uncertainty for the calculated result, r , is expressed as

$$\partial_r = \left[\left(\frac{\partial r}{\partial X_1} \times \delta x_1 \right)^2 + \left(\frac{\partial r}{\partial X_2} \times \delta x_2 \right)^2 + \left(\frac{\partial r}{\partial X_3} \times \delta x_3 \right)^2 + \dots \right]^{0.5} \quad \text{----(1)}$$

Where:

∂_r = Uncertainty in the result

δx_i = Uncertainties in the measured variable X_i

$\frac{\partial r}{\partial X_i}$ = Absolute sensitivity coefficient

In order to simplify the uncertainty analysis, so that it can be done on simple spreadsheet applications, each term on RHS of the equation-(1) can be approximated by:

$$\frac{\partial r}{\partial X_1} \times \partial X_1 = r(X_1 + \partial X_1) - r(X_1) \quad \text{----(2)}$$

The basic spreadsheet is set up as follows, assuming that the result r is a function of the four parameters X_1, X_2, X_3 & X_4 . Enter the values of X_1, X_2, X_3 & X_4 and the formula for calculating r in column A of the spreadsheet. Copy column A across the following columns once for every variable in r (see table 7.1). It is convenient to place the values of the uncertainties $\partial(X_1), \partial(X_2)$ and so on in row 1 as shown.

Table 7-1: Uncertainty evaluation sheet-1

	A	B	C	D	E
1		∂X_1	∂X_2	∂X_3	∂X_4
2					
3	X_1	X_1	X_1	X_1	X_1
4	X_2	X_2	X_2	X_2	X_2
5	X_3	X_3	X_3	X_3	X_3
6	X_4	X_4	X_4	X_4	X_4
7					
8	$y=f(X_1, X_2, X_3, X_4)$	$y=f(X_1, X_2, X_3, X_4)$	$y=f(X_1, X_2, X_3, X_4)$	$y=f(X_1, X_2, X_3, X_4)$	$y=f(X_1, X_2, X_3, X_4)$

Add ∂X_1 to X_1 in cell B3 and ∂X_2 to X_2 in cell C4 etc., as in Table 7.2. On recalculating the spreadsheet, the cell B8 becomes $f(X_1 + \partial X_1, X_2, X_3, X_4)$.

Table 7-2: Uncertainty evaluation sheet-2

	A	B	C	D	E
1		∂X_1	∂X_2	∂X_3	∂X_4
2					
3	X_1	$X_1 + \partial X_1$	X_1	X_1	X_1
4	X_2	X_2	$X_2 + \partial X_2$	X_2	X_2
5	X_3	X_3	X_3	$X_3 + \partial X_3$	X_3
6	X_4	X_4	X_4	X_4	$X_4 + \partial X_4$
7					
8	$r=f(X_1, X_2, X_3, X_4)$	$r=f(X_1', X_2, X_3, X_4)$	$r=f(X_1, X_2', X_3, X_4)$	$r=f(X_1, X_2, X_3', X_4)$	$r=f(X_1, X_2, X_3, X_4')$

In row 9 enter row 8 minus A8 (for example, cell B9 becomes B8-A8). This gives the values of $\partial (r, X_1)$ as shown in table 7.3.

$$\partial (r, X_1) = f(X_1 + \partial X_1, X_2, X_3, \dots) - f(X_1, X_2, X_3, \dots) \text{ etc.}$$

To obtain the standard uncertainty on y , these individual contributions are squared, added together and then the square root taken, by entering $\partial (r, X_1)^2$ in row 10 (Figure 7.3) and putting the square root of their sum in A10. That is, cell A10 is set to the formula, $\text{SQRT}(\text{SUM}(\text{B}10+\text{C}10+\text{D}10+\text{E}10))$ which gives the standard uncertainty on r , $\partial (r)$

Table 7-3: Uncertainty evaluation sheet-3

	A	B	C	D	E
1		∂X_1	∂X_2	∂X_3	∂X_4
2					
3	X_1	$X_1 + \partial X_1$	X_1	X_1	X_1
4	X_2	X_2	$X_2 + \partial X_2$	X_2	X_2
5	X_3	X_3	X_3	$X_3 + \partial X_3$	X_3
6	X_4	X_4	X_4	X_4	$X_4 + \partial X_4$
7					
8	$r=f(X_1, X_2, X_3, X_4)$	$r=f(X_1', X_2, X_3, X_4)$	$r=f(X_1, X_2', X_3, X_4)$	$r=f(X_1, X_2, X_3', X_4)$	$r=f(X_1, X_2, X_3, X_4')$
9		$\partial (r, X_1)$	$\partial (r, X_2)$	$\partial (r, X_3)$	$\partial (r, X_4)$
10	$\partial (r)$	$\partial (r, X_1)^2$	$\partial (r, X_2)^2$	$\partial (r, X_3)^2$	$\partial (r, X_4)^2$

Uncertainty analysis for Dryer efficiency Testing cont'd..

Heat for sensible heat supply to the liquid in solids (inlet to evaporating temperature) $H_{in} = W \times m_{in} \times C_{pl} \times (T_{sout} - T_{sin})$	kJ/s or kJ/batch	50.28	52.794	51.286	50.28	49.78	51.2856	50.28	50.28	50.28	50.28
Heat for vaporization of liquid at evaporating temperature, $H_{lv} = W \times (m_{in} - m_{out}) \times L_e$	kJ/s or kJ/batch	677.22	711.08	695.28	672.71	677.2	677.22	677.22	677.22	677.22	677.22
Heat for superheating of evaporated vapour (from evaporating temperature to product temperature) $H_{esup} = W \times (m_{in} - m_{out}) \times C_{pv} \times (T_{out\ tdb} - T_{out\ wb})$	kJ/s or kJ/batch	4.5252	4.7515	4.6459	4.495	4.525	4.5252	4.5252	5.034285	4.061367	4.5252
Heat input, H_{in}	KJ/s or kJ per batch	1642.2	1642.2	1642.2	1642.2	1642	1642.2	1642.2	1642.2	1642.2	1724.31
Dryer efficiency, $\eta =$	%	0.4457	0.468	0.4574	0.443	0.445	0.4463	0.4457	0.4460	0.4454	0.4245
Delta			0.0223	0.0117	-0.003	-0	0.000612	0	0.00031	-0.00028	-0.02123
Delta square			0.0005	0.0001	8E-06	9E-08	3.75E-07	0	9.61E-08	7.98E-08	0.000451
Sum of delta square			0.0011								
Square root of sum of delta square			0.033								
% uncertainty			7.4%								

Comments:

- Note that the uncertainty in dryer efficiency is 7.4% for the given set of accuracy of instruments
- The accuracy of steam flow measurements, material flow measurements and moisture content measurement in material has significant impact on the dryer efficiency.
- If the accuracy of steam flow can be improved to 2% from the given figure of 5% used in the above table, uncertainty will reduce from 7.4% to 6%.
- In addition to the above, if material flow accuracy is improved to 2% (from given value of 5%) and material moisture content measurement accuracy to 1% (from given value of 2%), the overall uncertainty can be reduced to 3.1%.
- Air temperature measurements do not have much impact on overall uncertainty.

8 GUIDE TO IDENTIFYING ENERGY SAVING OPPORTUNITIES

8.1 Background

The essential requirement for identifying energy saving potential in a dryer is first to develop a drying curve for the dryer under consideration. The drying curve is a plot of drying rate, N ($\text{kg}/\text{m}^2/\text{h}$) and moisture content. In the most general cases, the drying rates vary throughout the dryer with time as drying proceeds, and with the changing moisture content of the material. The drying rate is measured as moisture lost in unit time. Figure 8.1 shows a typical drying curve.

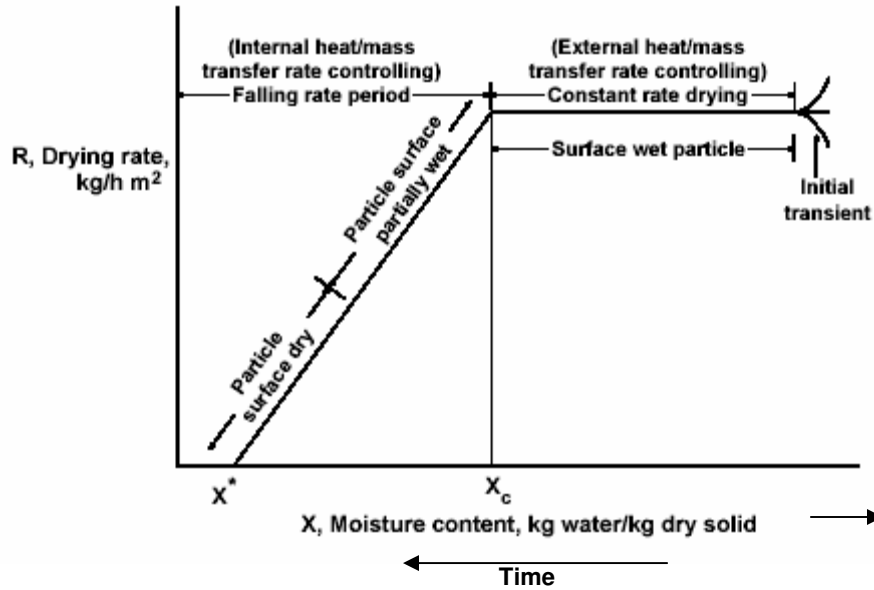

Figure 8-1: Drying curve

The fundamental factor for energy saving in drying operation is to match the energy supply to the dryer with the varying drying kinetics.

The following figure is a typical drying curve of a spray dryer used for drying food products.

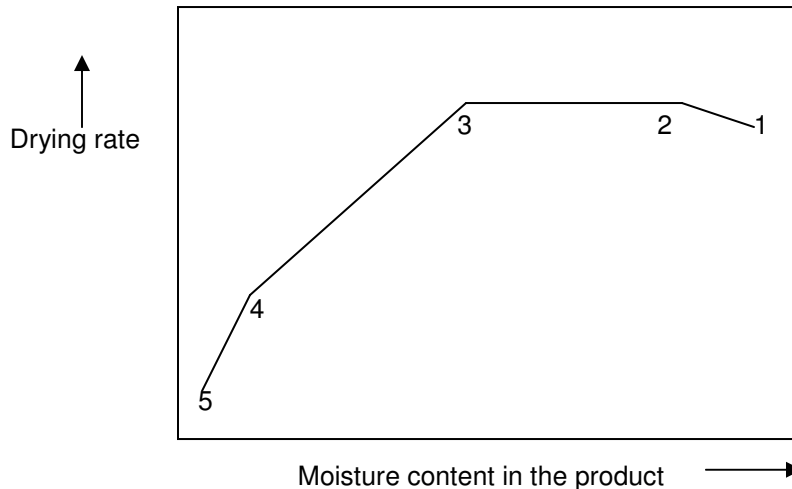

Figure 8-2: drying curve for spray drying of food

In the above figure, the drying rate is almost constant as long as unbound moisture is present and surface of product is saturated (1-2-3). A critical point (3) is reached when diffusion and capillary flow in the spray droplet can no longer maintain these conditions. The drying rate then declines until equilibrium moisture levels are reached (5).

The three characteristics of air that are necessary for successful drying in the constant rate period are;

- 1) A moderately high dry bulb temperature.
- 2) A low relative humidity.
- 3) A high air velocity.

The following points are helpful in evaluating energy saving potential in a dryer.

1. The constant rate drying is influenced by temperature of the drying agent (typically air) and flow rate. That is, for a convection dryer, higher air inlet temperature and airflow enhances drying in the constant rate period.
2. The falling rate period drying is a much slower process, influenced by the internal moisture transportation properties of the material. Generally, the falling rate of drying do not require high temperature or airflow.

Hence it is possible to establish control systems based on the above principles. In a given dryer, first establish the drying curve for a product, by observing the moisture content variations, drying rate and time. From the curve, suitable control logic can be established as to which time period require higher temperature, airflow etc. (constant rate drying) and the time and moisture content zones when temperature and airflow can be lowered.

It is also possible to have multistage drying in which a spray dryer in the 1st stage followed by a fluidised bed dryer for 2nd stage. Spray dryer is essentially very good for high temperature, fast drying of products, which is a constant rate drying process. In the second stage, more residence time is allowed in a fluidised bed with less demanding temperature conditions. Specific energy consumption have reduced from 5500 J/kg of water evaporation to 3600 J/kg by multi-staging dryers and using suitable controls.

8.2 Diagnostics

After estimating the efficiency of the dryer, the following steps may be followed:

- Comparison of the estimated efficiency with achievable efficiency values from reliable literature. The following table 8.1 gives the expected dryer efficiencies and specific energy consumption.

Table 8-1: Expected Dryer Efficiencies

Dryer group and type	Typical Heat loss sources	Typical efficiency
Rotary		
□ Indirect Rotary	Surface	28 – 75%
□ Cascading Rotary	Exhausts, leaks	19 – 64%
Band, Tray & Tunnel		
□ Cross circulated tray/oven/band	Exhaust, surface	14 – 28%
□ Cross circulated shelf / tunnel	Exhaust, surface	14 – 38%
□ Through circulated tray / band	Exhaust	19 – 45%
□ Vacuum tray / band / plate	Surface	28 – 64%
Drum	Surface	19 – 75%
Fluidised / Sprouted bed	Exhaust	28 – 64%
Spray		
□ Pneumatic conveying/Spray	Exhaust	28 – 64%
□ Two stage	Exhaust, surface	38 – 68%
□ Cylinder	Surface	23 – 64%
Stenter	Exhaust	19 – 45%

- Develop material and heat balance to understand major areas of losses.
- Understand dryer utilization and productivity i.e. feed rates or batch sizes vis-à-vis dryer rated capacity, batch cycle time etc.
- Review dryer instrumentation and control i.e. availability of instrumentation, control methods (manual or automatic), recording of energy consumption, practice for monitoring of moisture content in feed and product etc.
- Check for fouling of heat exchangers.

8.3 Energy Conservation Opportunites

Some tips for saving energy are listed to help identify energy conservation opportunities.

Load Reduction

- Reduce dryer load by mechanical dewatering by squeezing, centrifuges, filter presses, gas blowing etc.

House Keeping

- Avoid steam leaks.
- Check steam traps regularly.
- Repair doors and seals to avoid air leaks.
- Clean air filters and fan blades regularly to ensure proper air flow.
- Check fan speeds and belt slippage.
- Check heat transfer surfaces for fouling and high pressure drops.
- Check burner combustion efficiency.
- Improve insulation wherever needed.
- Explore the possibility of superheated steam drying.

Instrumentation & Control

- Moisture content measurement in material at the inlet and exit.
- Temperature at exhaust.
- Humidity at exhaust.

- Quality control in product – for uniform moisture, avoiding discolouration, curing/heat setting, preservation of useful characteristics of material – to predetermined level and its check.

Heat Recovery

- By recycling of exhaust air
- Use of appropriate heat exchangers i.e. tubular recuperators, plate heat exchangers, heat wheels, heat pipes etc.
- Use of heat pumps

Alternative Drying Methods

- Direct heating by fuel firing and heating with exhaust gases, if permissible.
- Infrared heating, especially with gas fired infrared heaters.
- Dielectric heating – Radio frequency or Microwave heating.

ANNEXURE-1: HEAT AND MASS BALANCE CALCULATIONS OF DRYER

A1.1. Balance of Dry Solids

$$W_{in} = W_{out} + W_{dust} \text{ ----- (1)}$$

Where W_{in} : Bone dry solid material input to a dryer, kg/s.
 W_{dust} : Bone dry solid material from the dust collector, kg/s.
 W_{out} : Bone dry solid material output from dryer proper, kg/s.

A1.2. Moisture Balance

$$W_{in} \times m_{in} = W_{out} \times m_{out} + W_{dust} \times m_{dust} + E \text{ ----- (2)}$$

Where m_{in} : Moisture in feed, kg/kg bone dry material.
 m_{dust} : Moisture in dust collector material output, kg/kg bone dry material
 m_{out} : Moisture in dried product output of dryer proper, kg/kg bone dry material.
 E : Evaporation, kg/kg bone dry material

A1.3. Dry Air Mass Flow/Air Infiltration

$$V_{h-in} = (0.00283 + 0.00456 \times h_{in}) \times (T_{in} + 273) \text{ ----- (3)}$$

$$G_{in} = \frac{V_{in}}{h_{v-in}} \text{ ----- (4)}$$

$$V_{h-out} = [0.00283 + 0.00456 \times H_{out}] \times [T_{out} + 273] \text{ ----- (5)}$$

$$G_{out} = \frac{V_{in}}{h_{v-out}} \text{ ----- (6)}$$

$$G_{leak} = G_{out} - G_{in} \text{ ----- (7)}$$

where
 V_{in} : Inlet air flow to dryer, m³/s
 V_{out} : Exhaust air flow from dryer proper, m³/s

A1.4. Moisture Gained by Drying Gas

$$G_{evpn} = G_{out} \times h_{out} - G_{in} \times h_{in} - G_{leak} \times h_{amb} \text{ ----- (8)}$$

A1.5. Evaporation

$$E = W_{in} \times m_{in} - W_{out} \times m_{out} - W_{dust} \times m_{dust} \text{ ----- (9)}$$

Check: $G_{evpn} = E \pm 10\% E$

A1.5. Hot Air Input to Dryer from a Single furnace/heater arrangement

$$G_{in} = G_{comb} + G_{add}$$

Where,
 $G_{add} = V_{add} / V_{h-amb}$, and
 $V_{h-amb} = [0,00283 + 0,00456 \times H_{amb}] \times [T_{amb} + 273]$

$$G_{\text{comb}} = V_{\text{comb}}/V_{\text{h-amb}}$$

A1.6. Heat Input to Dryer

$$H_{\text{in}} = G_{\text{in}} \times C_{\text{h-in}} \times [T_{\text{in}} - T_{\text{amb}}]$$

Where,

$$C_{\text{h-in}} = 1.0 + 1.88 \times H_{\text{in}}$$

H_{in} In Watts for electrically heated system

$H_{\text{in}} = Q \times C_{\text{p-TF}} \times [(T_{\text{in-TF}} - T_{\text{out-TF}})]$, if thermic fluid heated system

$H_{\text{in}} = FC \times FHV \times C_{\text{eff}}$, KJ/s., for direct fired system or steam heating

$$H_{\text{in}} = H_{\text{tot}} + H_{\text{ul}}$$

Where, H_{ul} can be 5, 10, 15 or 20 % of H_{tot} based on experience.

A1.7. Heat Outputs

$$\begin{aligned} H_{\text{s}} &= \text{Heat given to solids dried} \\ &= w_{\text{out}} \times C_{\text{ps}} \times [T_{\text{s-out}} - T_{\text{s-in}}] + w_{\text{dust}} \times C_{\text{ps}} \times [T_{\text{s-dust}} - T_{\text{s-in}}] \end{aligned}$$

$$\begin{aligned} H_{\text{lh}} &= \text{Heat for sensible heating of liquid} \\ &= [w_{\text{out}} + w_{\text{dust}}] \times m_{\text{in}} \times C_{\text{pl}} \times [T_{\text{wb}} - T_{\text{s-in}}] \end{aligned}$$

$$\begin{aligned} H_{\text{lv}} &= \text{heat for vaporization of liquid} \\ &= [w_{\text{out}} \times [m_{\text{in}} - m_{\text{out}}]] \times L_{\text{e}} + w_{\text{dust}} \times [m_{\text{in}} - m_{\text{dust}}] \times L_{\text{e}} \end{aligned}$$

$$\begin{aligned} H_{\text{md}} &= \text{Heat for moisture in dried product} \\ &= w_{\text{out}} \times m_{\text{out}} \times [T_{\text{s-out}} - T_{\text{wb}}] + w_{\text{dust}} \times m_{\text{dust}} \times [T_{\text{s-dust}} - T_{\text{wb}}] \end{aligned}$$

$$\begin{aligned} H_{\text{esup}} &= \text{Heat for superheating of evaporated vapours upto exhaust gas temperature} \\ &= w_{\text{out}} \times [m_{\text{in}} - m_{\text{out}}] \times C_{\text{pV}} \times [T_{\text{out}} - T_{\text{wb}}] + w_{\text{dust}} \times [m_{\text{in}} - m_{\text{dust}}] \times C_{\text{pV}} \times [T_{\text{out}} - T_{\text{wb}}] \end{aligned}$$

$$\begin{aligned} H_{\text{rc}} &= \text{Heat for reaction and crystallization} \\ &= w_{\text{in}} \times [H_{\text{rx}} + H_{\text{crys}}] \end{aligned}$$

$$\begin{aligned} H_{\text{sl}} &= \text{Heat for convective and radiative losses from insulated/uninsulated surfaces} \\ &= R_1 \times A_1 + R_2 \times A_2 + \dots \dots \dots \text{etc.} \end{aligned}$$

Where A_1, A_2 etc. are total areas temperatures and R_1, R_2, \dots etc. are rates of surface heat losses based on.

$$\text{Surface Heat Loss, kJ/m}^2 \times \text{s, } R = 1.163 \times 10^{-3} [10 + (T_{\text{s}} - T_{\text{a}})/20] (T_{\text{s}} - T_{\text{a}})$$

Where, T_{s} and T_{a} are the surface temperatures and ambient air temperature

$$\begin{aligned} H_{\text{h}} &= \text{heat lost in condensate} \\ &= SC \times [h - T_{\text{amb}}] \end{aligned}$$

Total heat utilized in dryer,

$$H_{\text{tot}} = (H_{\text{s}} + H_{\text{lh}} + H_{\text{lv}} + H_{\text{md}} + H_{\text{esup}} + H_{\text{rc}} + H_{\text{sl}} + H_{\text{h}})$$

Unaccounted losses, $H_{\text{ul}} = (H_{\text{in}} - H_{\text{tot}})$ kJ/s.

$$\text{Dryer thermal efficiency} = H_{\text{tot}} / H_{\text{in}} \times 100$$

A1.8. Sample calculations

A sample calculation is given below indicating the measurements and calculations involved in estimation of heat balance and dryer efficiency.

Table A1-0-1: Measurements

Parameter	Unit	Qty	Symbol
Date			
Trial Time			
Dry solids output			
From product chamber	kg/hour	792.2	W_{out}
From Dust collector	kg/hour	24.5	W_{dust}
Moisture in material			
At inlet	kg/kg of bone dry product	1.5	m_{in}
In final product	kg/kg of bone dry product	0.0528	m_{out}
In dust collector	kg/kg of bone dry product	0.04	m_{dust}
Temperature of material			
At inlet	Deg. C	21.1	T_{s-in}
In final product	Deg. C	82.2	T_{s-out}
In dust collector	Deg. C	93.3	T_{s-dust}
Specific heat of materials			
Specific heat of solid material	kJ/kg-C	1.8855	C_{p-s}
Specific heat of liquid material	kJ/kg-C	4.19	C_{p-l}
Specific heat of vapour	kJ/kg-C	1.8855	C_{p-v}
Volume of air			
Air inlet to electrical heater	m^3/h	22104	$V_{primary}$
Air outlet from electrical heater into dryer	m^3/h	37926	V_{in}
Dryer outlet gas	m^3/h	30402	V_{out}
Air temperature measurements			
Drybulb temperature of ambient air	$^{\circ}C$	21.1	T_{a-db}
Wetbulb temperature of ambient air	$^{\circ}C$	15.5	T_{a-wb}
Hot air at electrical heat outlet	$^{\circ}C$	232.6	T_{in}
Drybulb temperature of exhaust from dryer	$^{\circ}C$	105.0	T_{out-db}
Wetbulb temperature of exhaust from dryer	$^{\circ}C$	41.7	T_{out-wb}
Drybulb temperature of exhaust from dust collector	$^{\circ}C$	101.67	T_{exh}
Latent heat at WBT	kJ/kg	2402.7	L_e
Humidity in Air			
In ambient air	kg/kg of dry air	0.0126	h_a
In hot air inlet of dryer	kg/kg of dry air	0.0126	h_{in}
In exhaust air	kg/kg of dry air	0.0581	h_{out}

Listing of computations:

$$h_{vout} = [0.00283 + 0.00456 \times h_{out}] \times (T_{out} + 273)$$

$$h_{vin} = [0.00283 + 0.00456 \times h_{in}] \times (T_{in} + 273)$$

$$G_{out} = \frac{V_{out}}{h_{vout}}$$

$$G_{in} = \frac{V_{in}}{h_{vin}}$$

$$G_{leak} = G_{out} - G_{in}$$

$$G_{evpn} = G_{out} \times h_{out} - (G_{in} \times h_{in} + G_{leak} \times h_{amb})$$

$$E = m_{in} \times w_{in} - (m_{out} \times w_{out} + m_{dust} \times w_{dust})$$

Check: $G_{evpn} = E$

$$w_{in} = w_{out} + w_{dust}$$

$$h_{vamb} = [0.00283 + 0.00456 \times h_{amb}] \times (T_{amb} + 273)$$

$$G_{primary} = \frac{V_{primary}}{h_{vamb}}$$

Check: $G_{primary} = G_{in}$

$$C_{hin} = 1.0 + (1.88 \times h_{in})$$

$$H_{in} = G_{in} \times C_{hin} \times (T_{in} - T_{amb})$$

$$EC_c = H_{in} / (3600 \times 0.95)$$

$$H_s = w_{out} \times C_{ps} \times (T_{out} - T_{in}) + w_{dust} \times C_{ps} \times (T_{dust} - T_{in})$$

$$H_{lh} = (w_{out} + w_{dust}) \times m_{in} \times C_{pl} \times (T_{outwb} - T_{sin})$$

$$H_{lv} = w_{out} \times (m_{in} - m_{out}) \times L_e + w_{dust} \times (m_{in} - m_{dust}) \times L_e$$

$$H_{md} = w_{out} \times m_{out} \times (T_{sout} - T_{outwb}) + w_{dust} \times m_{dust} \times (T_{sdust} - T_{outwb})$$

$$H_{esup} = w_{out} \times (m_{in} - m_{out}) \times C_{pv} \times (T_{out} - T_{outwb}) + w_{dust} \times (m_{in} - m_{dust}) \times C_{pv} \times (T_{out} - T_{outwb})$$

$$H_g = G_{in} \times C_{hin} \times (T_{in} - T_{out})$$

$$H_{total} = H_{lh} + H_{lv} + H_{esup} + H_s + H_{md}$$

$$H_R = H_g - H_{total}$$

$$H_{exh} = H_{in} - (H_{total} + H_R)$$

$$\text{Thermal efficiency} = \frac{(H_{lh} + H_{lv} + H_{esup})}{H_{in}}$$

Table A1.2: Computation of results

Parameter	Unit	Qty	Symbol
Humid volume at dryer outlet	m ³ mixture/kg dry gas	1.17	h_{v-out}
Humid volume at dryer inlet	m ³ mixture/kg dry gas	1.46	h_{v-in}
Dry air mass flow at dryer outlet	kg/hr	25984.6	G_{out}
Dry air mass flow at dryer inlet	kg/hr	225976	G_{in}
Air leaks into the dryer	kg/hr	8.6	G_{leak}
Moisture gain by drying gas	kg/hr	1182.2	G_{evap}
Dryer evaporation	kg/hr	1182.2	E
Air mass flow to heater	kg/hr	26005	$G_{primary}$
Humid volume at inlet to heater	kg/hr	0.85	h_{vamb}
Air mass flow to heater	kg/hr	25976	G_{mh}
Average humid heat across heater	kJ/kg of dry air	1.0237	C_{h-in}
Heat required to heat inlet air	kJ/hr	5624130	H_{in}
Calculated heater power with 95% efficiency	kW	1644	W_{in}

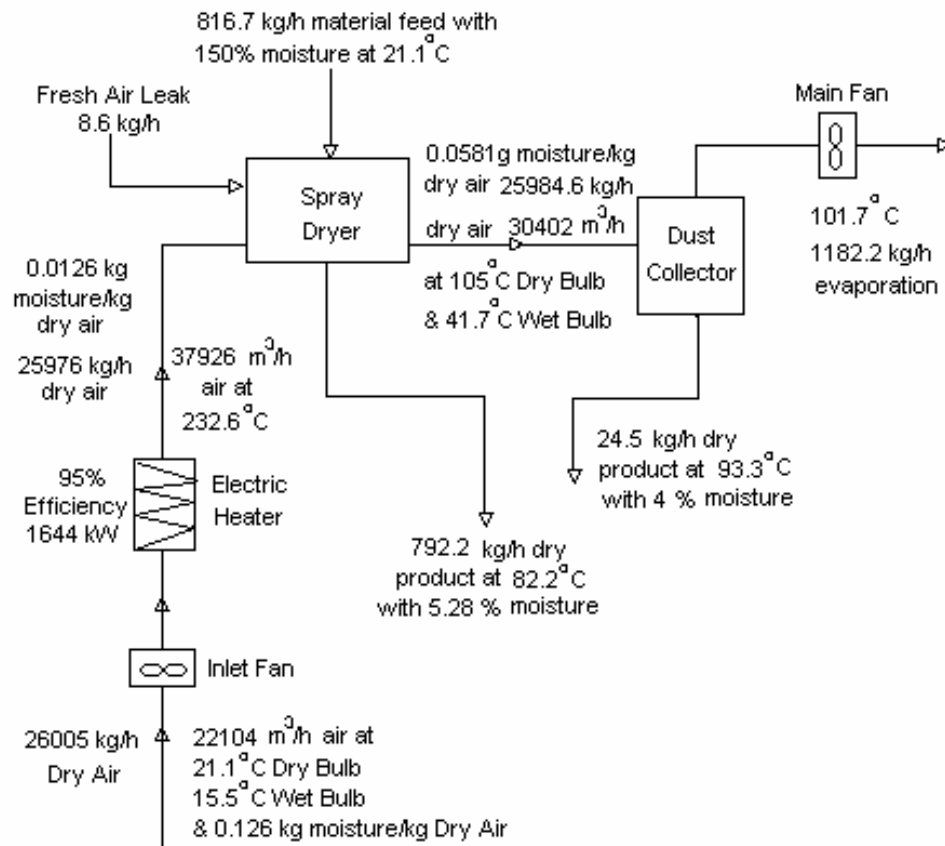

Figure A1-0-1: Flow diagram

Table A1-2: Dryer heat balance

Parameter	Unit	Qty	% Of Heat Input	Symbol
Heat input from electrically heated hot air from atmosphere at 95% efficiency of water	kJ/h	5624130	100	H_{in}
I Heat for liquid evaporation (i) Heating from inlet to WBT (ii) Vapourising at WBT (iii) Heating vapours from WBT to gas outlet temperature	kJ/h kJ/h kJ/h	105739 2840573 139766	1.87 50.28 2.47	H_{eh} H_{lv} H_{esvp}
Sub Total I	kJ/h	3086078	54.87	Dryer thermal efficiency
II Heat for outgoing (i) solid product form inlet to outlet (ii) moisture in dried product from inlet to outlet	kJ/h kJ/h	94599 1745	1.67 0.03	H_s H_{md}
Sub Total II	kJ/h	96344	1.7	Heat lost in outgoing material
III Heat absorbed by dryer from gas flow before exhaust	kJ/h	3395147	60.37	H_g
IV Unaccounted loss (H_g -Subtotal I + Subtotal II) (due to radiation)	kJ/h	212725	3.78	Radiation loss H_R
V Heat lost in exhaust [$H_{in} - (\text{subtotal I} + \text{subtotal II} + H_R)$]	kJ/h	2228843	39.63	Exhaust loss H_{exh}

Dryer heat balance is shown in figure-A1.2.

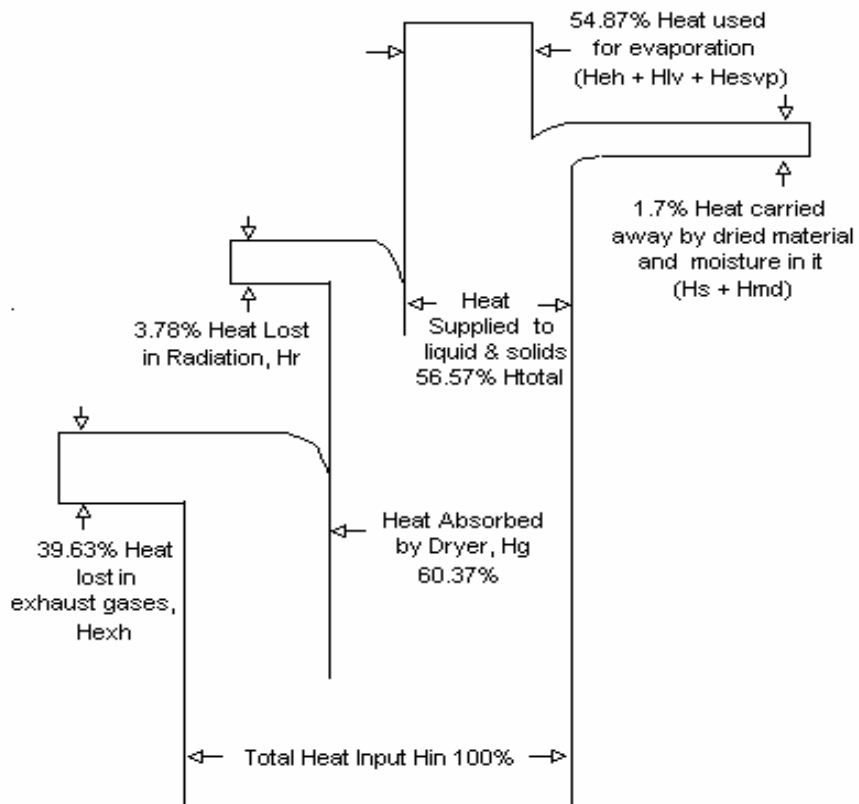

Figure A1-2: Sankey diagram for energy flow

ANNEXURE 2: SI UNITS, CONVERSION FACTORS & PREFIXES

QUANTITY	SI UNITS	CONVERSION FACTORS
Length	m	1 ft = 0.3048 m 1 inch = 0.0254 m
Mass	kg	1 ton (metric) = 1000 kg 1 lb = 0.454 kg
Time	s	1 h = 3600 sec
Electric Current	A	Ampere
Thermodynamic Temperature	K	$t^{0C} = (t + 273.15) \text{ k}$ $t^{0F} = \frac{[(t - 32) + 273.15]}{1.8}$
Amount of substance	mol	mole
Luminous intensity	cd	candela
Acceleration	m/s^2	$1 \text{ ft/s}^2 = 0.3048 \text{ m/s}^2$
Area	m^2	$1 \text{ ft}^2 = 0.0929 \text{ m}^2$
Density	kg/m^3	$1 \text{ ton / m}^3 = 10^3 \text{ kg/ m}^3$ $1 \text{ lb / ft}^3 = 16.02 \text{ kg/ m}^3$
Diffusion coefficient	m^2/s	$1 \text{ ft}^2/\text{s} = 0.0929 \text{ m}^2 / \text{s}$
Force (weight)	N (Newton) Kg-m/s^2	1 kgf = 9.81N 1 lbf = 4.45N
Specific heat (Of phase change)	J /kg	1 kcal /kg = 4190 J/kg 1 Btu = lb = 2326 J /kg
Surface tension	N/m	1 kgf / m = 9.81 N/m = 9.81 J/m ²
Thermal conductivity	W/m.k	1 kcal/ h-m-k = 1.163 W/m.k 1 Btu/ Ft-h- ⁰ F = 1.73 W/m.k
Viscosity, dynamic	Pa.s	1 pa = 0.1 pa 1 cp = 10 ⁻³ pa
Viscosity, kinematics	m^2 / s	1 st = 10 ⁻⁴ m ² /s 1 ft ² /s = 0.093 m ² /s
Volume	m^3	1 ft ³ = 0. 02831685 m ² /s
Work, Energy, Quantity of heat	J (joule) N-m	1 kgf-m = 9.80665 N 1 kWh = 3.6x 10 ⁶ J 1kcal = 4.19 kJ 1 lb-ft = 1.356 J 1 Btu = 1055.1 J
Luminous Flux	lm (lumen)	cd-Sr

QUANTITY	SI UNITS	CONVERSION FACTORS
Solid angle	Sr	Steradian
Frequency	Hz (Hertz)	1 rps = 1 Hz
Heat (enthalpy) Specific energy	J/kg	1 kcal/kg = 4190 J/kg
Heat capacity (Entropy)	J/kg	1 Btu/lb = 2326 J/kg
Heat capacity, specific (Also specific entropy)	J/kg .K	1 kcal/kg .K= 4190 J/kg 1 Btu /lb- ⁰ F = 4190 J/kg-k
Heat transfer coefficient	W/ m ² .k	1 kcal/m ² -h-k = 1.163 W/ m ² -K 1 Btu/ft ² -h- ⁰ F = 5.6 W/ m ² -k
Power (radiant flux)	W (watt) J/s	1 kcal/ h = 1.163 W 1 kgf-m/s= 9.81 W 1 lb-ft/s =1.356 W
Pressure	Pa (Pascal) N/m ²	1 bar = 10 ⁵ pa 1 kgf/ cm ² = 1 atm = 735 mm Hg = 9.81 x 10 ⁴ Pa 1 atm = 760 mmHg = 101325 Pa 1 mmH ₂ O = 9.81Pa 1mm Hg = 133.3 Pa 1 lbf /in ² (psi) = 6894.76 Pa
Rate of flow, mass	kg/ s	1 lb/s = 0.454 kg/s
Rate of flow, volumetric	m ³ /s	1 ft ³ /s = 28.3 x 10 ⁻³ m ³ /s

Some S.I prefixes are as follows:

Kilo	K	10 ³	deci	d	10 ⁻¹
Mega	M	10 ⁶	centi	c	10 ⁻²
Giga	G	10 ⁹	milli	m	10 ⁻³
Tera	T	10 ¹²	micro		10 ⁻⁶
			nano	n	10 ⁻⁹
			pico	P	10 ⁻¹²

ANNEXURE 3: REFERENCES

1. Guide to industrial drying- A.S. Mujumdar
2. AIChE (American Institute of Chemical Engineers) – Equipment Testing procedure: 1988: Spray Dryers- A guide to performance evaluation
3. AIChE (American Institute of Chemical Engineers) – Equipment Testing procedure: 1968: Rotary Continuous Direct Heat Dryers
4. ASTM-D 644-99: Standard test method for Moisture Content in Paper and Paper board by Oven Drying
5. IS : 6637-1972: Method for determination of Moisture in Wool
6. IS : 5436-1969: Method of testing oil fired rotary dryers for hot mix asphalt
7. IS : 11620-1986: Code of Practice for Fluidised Bed Dryers
8. IS :13859- 1993: Instant Tea in solid form -Determination of moisture content
9. IS: 199-1989: Textiles- Estimation of Moisture content