

TENDER DOCUMENT

**NEW AND RENEWABLE ENERGY DEVELOPMENT
CORPORATION OF ANDHRA PRADESH LTD (NREDCAP)**

Inviting bids for

**Supply and Maintenance of 945 numbers of electric 2- Wheelers
with Carriage box to Health Medical & Family Welfare
Department, Mangalagiri and its delivery locations.**

Tender No: NREDCAP/EV/H&M/17-106/945/2021-22

Dated: 31.03.2022

(REVERSE E-TENDERING)

(Ref : NREDCAP/EV/H&M/17-106/945/2021-22, DATED:31.03.2022)

NAME OF THE FIRM: _____

Issued by

New and Renewable Energy Development of AP Ltd,

Regd.Office: 12-464/5/1, River Oaks Apartment, CSR Kalyana Mandapam Road, Tadepalli,
Guntur District

Tel: 0863 -2347650 /651/652/653; E-mail:info@nredcap.in

gmtech@nredcap.in, ev@nredcap.in

INDEX

1	INTRODUCTION AND BACKGROUND	6
1.1.	INTRODUCTION	6
1.2.	BACKGROUND	6
2	DEFINITIONS.....	7
3	BID INFORMATION AND INSTRUCTIONS TO BIDDERS.....	11
3.1.	OBTAINING BID DOCUMENT & BID PROCESSING FEES	11
3.2.	TIMELINES FOR BID PROCESS.....	11
4.	INFORMATION PERTAINING TO BID SUBMISSION VIA E PROCUREMENT PLATFORM.....	18
5.	PROJECT SCOPE	19
5.1.	QUALIFICATION REQUIREMENTS	20
5.2.	BID SUBMISSION.....	22
5.3.	FINANCIAL BID	24
5.4.	EARNEST MONEY DEPOSIT (EMD) AND PERFORMANCE GUARANTEE (PG)	25
5.5.	PAYMENT TERMS.....	26
5.6.	CLARIFICATIONS/PRE-BID MEETING/ENQUIRES/AMENDMENTS.....	26
5.7.	FRAUDULENT AND CORRUPT PRACTICES.....	26
5.8.	E-AUCTION (REVERSE TENDERING)	28
5.9.	CONCLUSION OF REVERSE TENDERING PROCESS:	29
5.10.	OTHER PROVISIONS	29
5.11.	INDEMNITY	29
6.	FORMATS.....	30
	FORMAT-I: COVERING LETTER TO PREQUALIFICATION CHECK.....	31
	FORMAT-II: COVERING LETTER.....	33
	FORMAT-III: FORMAT FOR POWER OF ATTORNEY.....	36
	FORMAT- IV: FORMAT FOR TECHNICAL ELIGIBILITY CRITERIA	38
	FORMAT- V: FORMAT FOR FINANCIAL ELIGIBILITY CRITERIA	39
	FORMAT- VI :FORMAT FOR FINANCIAL BID.....	40
	FORMAT –VII: FORMAT FOR BANK GUARANTEE	41
	FORMAT -VIII: DECLARATION REGARDING “RESTRICTIONS ON PROCUREMENT FROM A BIDDER OF A COUNTRY WHICH SHARES A LAND BORDER WITH INDIA”	42

BID for supply of 945 Numbers of Electric 2- Wheelers to Health Medical & Family Welfare Department, Mangalagiri, Guntur District

FORMAT – IX: CERTIFICATE REGARDING DECLARATION OF LOCAL CONTENT...	43
FORMAT - X	44
ANNEXURE - A: TECHNICAL SPECIFICATIONS OF ELECTRIC 2- WHEELERS	45
ANNEXURE –B: SERVICE LEVEL AGREEMENT (SLA)	46
ANNEXURE –C: DELIVERY DESTINATIONS	48
ANNEXURE –D: PICTORIAL REPRESENTATION OF BOX.....	49
CHECKLIST	50

I. DISCLAIMER

- a) The BID document is not transferable.
- b) This BID is issued by New & Renewable Energy Development Corporation of AP Ltd (NREDCAP).
- c) The Bid document is not a prospectus or offer on invitation to the public in relation to the sale of shares, debentures, or securities, nor shall this Bid document or any part of it form the basis of or be relied upon in any way in connection with, any contract relating to any shares, debentures or securities.
- d) In considering a response to this Request for Proposal (BID), each recipient should make its own independent assessment and seek its own professional, technical, financial and legal advice.

Whilst the information in this BID document has been prepared in good faith, it is not and does not purport to be comprehensive or to have been independently verified. Neither NREDCAP nor any of their officers or employees, nor any of their advisers nor consultants, accept any liability or responsibility for the accuracy, reasonableness or completeness of, or for any errors, omissions or misstatements, negligent or otherwise, relating to the proposed Project, or makes any representation or warranty, express or implied, with respect to the information contained in this document or on which this document is based or with respect to any written or oral information made or to be made available to any of the recipients or their professional advisers and, so far as permitted by law and except in the case of fraudulent misrepresentation by the party concerned, and liability therefore is here by expressly disclaimed.

- e) The information contained in this document is selective and is subject to updating, expansion, revision and amendment issued before due date. It does not, and does not purport to, contain all the information that a recipient may require. Neither NREDCAP nor any of their officers, employees nor any of its advisors nor consultants undertakes to provide any recipient with access to any additional information or to update the information in this document or to correct any inaccuracies therein which may become apparent. Each recipient must conduct its own analysis of the information contained in this document or to correct any inaccuracies therein that may be contained in this document and is advised to carry out its own investigation in relation to the

BID for supply of 945 Numbers of Electric 2- Wheelers to Health Medical & Family Welfare Department, Mangalagiri, Guntur District

Project(s)/Tender, the legislative and regulatory regime which applies thereto and by and all matters pertinent to the proposed Project/Tender and to seek its own professional advice on the legal, financial, regulatory and taxation consequences of entering into any agreement or arrangement relating to the proposed Project/Tender.

- f) This BID document, if includes certain statements, estimates, projections, designs, targets and forecasts with respect to the Project, such statements, estimates, projections, targets and forecasts, designs reflect various assumptions made by the management, officers and employees of NREDCAP, which assumptions (and the base information on which they are made) may or may not prove to be correct. No representation or warranty is given as to the reasonableness of forecasts or the assumptions on which they may be based and nothing in this document is, or should be relied on as a promise, representation or warranty.
- g) NREDCAP reserves the right to modify, amend or supplement or cancel this BID document, without any prior notice or without assigning any reason.

1 Introduction and Background

1.1. Introduction

Electric Vehicles (EV) refer to Automobiles using an electric motor that is driven by batteries, ultra capacitors or fuel cells. Electric motorcycles and scooters are plug-in electric vehicles with two or more wheels. The electricity is stored on board in a rechargeable battery, which drives electric motors.

1.2. Background

India is at the cusp of an e-mobility revolution. The Government of India is moving towards accelerated adoption of Electric Vehicles (EVs) by 2030 to cut down its carbon emissions. NREDCAP is the State Nodal Agency for implementation of all Renewable Energy Programs as well Electric Mobility in the State of Andhra Pradesh. Under E-mobility, NREDCAP is promoting various activities to promote adoption of E-Vehicles to conserve the petroleum products and to minimize the vehicular pollution. As per the E-Mobility policy of the Govt. of A.P. vides G.O.MS. No.74, dated 08.06.2018 of Industries and Commerce (P&I) Department targeted to phase out all fossil fuel based commercial fleets and logistics vehicles in top 4 cities by 2024 and all cities by 2030..Health department, Government of Andhra Pradesh is proposed to extend doorstep delivery/collection of samples from patients and as well deliver the medicines through their staff with electric two wheeler scooter is fitted with carriage box of two separate bins to carry samples and medicines from collection point to diagnosis center as well as hospitals to patients residences

2 Definitions

Any capitalized term, used but not defined in this BID, shall have the meaning as prescribed to such term in the Agreement. In absence of availability of definitions in the fore going references, the capitalized terms shall be interpreted in accordance with the CMVR Act 1989, Electricity Act 2003 and any other subsequent act, Regulations of the Appropriate Commission (Terms and Conditions, Grid Code or any other relevant electricity law, Ministry of Road Transport and Highways, AP Transport, CEA/ DISCOMs rules or regulations prevalent in India, as amended or re-enacted from time to time, in that order. Notifications, policies, guidelines as notified or amended from time to time)

Following terms used in the document will carry the meaning and interpretations as described below:

“Associate Company” shall mean in relation to another company, means a company in which that other company has a significant influence, but which is not a subsidiary company of the company having such influence and includes a joint venture company, as per Companies Act 2013. Significant influence shall mean control of at least twenty percent of total share capital, or of business decisions under an agreement.

“Authorized Representative” shall mean the body authorized to carry out the Bidding process for the selection of the Successful Bidder(s). As per this BID, NREDCAP is the authorized Representative.

“Cumulative Annual Turnover” shall have the same meaning as assigned to in Clause 5.1.1 of this BID.

“Bank Guarantee” shall mean the guarantees required to be furnished by the Bidder in accordance with the provisions of Clause 5.4(b) of this BID.

“Bid” shall mean the Bid submitted by the Bidder in accordance with provisions comprising of Technical Bid and Financial Bid in response to this BID, in accordance with the terms and conditions thereof.

“Bid Processing Fee” shall have the same meaning as per Clause 3.1(b) of this BID.

“Bidder” shall mean Bidding Company or a Bidding Firm submitting the Bid. Any reference to the Bidder includes Bidding Company/Bidding Firm.

BID for supply of 945 Numbers of Electric 2- Wheelers to Health Medical & Family Welfare Department, Mangalagiri, Guntur District

“**Bidding Company**” shall refer to such single Company, registered under Companies Act 1956 or Companies Act, 2013 as applicable that has submitted the response in accordance with the provisions of this BID.

“**Bid Dead line**” shall mean the last date and time for submission of Bid in response to this BID as specified in Clause 3.2 of the BID.

“**Bid Parameter**” shall have the same meaning as provided in this BID.

“**Bid Validity**” shall have the same meaning as provided in the BID.

“**Chartered Accountant**” shall mean a person practicing in India or a Firm wherein all the partners practicing in India are Chartered Accountant(s) within the meaning of the Chartered Accountants Act, 1949.

“**Comprehensive Maintenance Contract Period or CMC Period**” shall mean a period of 5 (Five) years/ 60 calendar months from the Date of Supply of Electric- 2 Wheelers.

“**Company**” shall mean a company incorporated under the Companies Act, 1956 or the Companies Act, 2013, as applicable.

“**Contract Period**” shall mean the period from the Effective Date till Expiry Date, in which the Agreement shall be valid.

“**Conflict of Interest**” A Bidder may be considered to be in Conflict of Interest with one or more Bidders in the same Bid process under this BID, if they have a relationship with each other, directly or indirectly through a common Company.

“**Date of Commissioning (DOC)**” shall mean the date on which the Electric 2- Wheelers is declared to be operational, provided that DOC shall not be achieved, and Electric 2- Wheelers shall not be operational until such Electric 2- Wheelers has satisfied the conditions as per the Agreement.

“**Effective Date**” shall mean the date of execution of Agreement by the Parties to the Agreement.

“**EMD**” Earnest Money Deposit.

“**Financial Bid**” shall mean the documents and formats as specified in Clause 5.3 of this BID.

BID for supply of 945 Numbers of Electric 2- Wheelers to Health Medical & Family Welfare Department, Mangalagiri, Guntur District

“**Financial Eligibility Criteria**” shall mean provisions of Clause 5.2 of this BID.

“**KW**” shall mean Kilowatts.

“**Letter of Award**” or “**LoA**” shall mean the letter issued by the Authorized Representative to the Successful Bidder for award of the Project. LoA shall provide details including but not limited to Allocated Quantity.

“**ICAT**” shall refer to International Centre for Automotive Technology.

“**ARAI**”: Automotive Research Association of India.

“**CMVR**”: Central Motor Vehicle Rules

“**CEA**”: Central Electricity Authority

“**DISCOMs**”: Power Distribution Companies

“**APSPDCL**”: Andhra Pradesh Central Power Distribution Company Limited

“**Performance Guarantee (PG)**” shall mean the Bank Guarantee furnished by the Developer, to assure timely and satisfactory completion of a Project by the OEM/Manufacturer as per the provisions of Agreement.

“**Quoted Price**” shall mean price quoted by the Bidder under Format VI of this BID that will be payable for supply and maintenance of Electric 2- Wheelers.

“**Qualified Bidder**” shall mean the Bidder (s) who, after evaluation of their Technical Bid(s) as per Clause 5.1 of the BID meet the Qualification Requirements and hence stand qualified for opening and evaluation of their Financial Bid(s).

“**Qualification Requirements**” shall mean the Pre-qualification criteria, General Eligibility Criteria, Technical Eligibility Criteria and Financial Eligibility Criteria as specified under Clause 5.1 of this BID.

“**Remote Monitoring Unit and IOT device for battery tracking and monitoring**” shall mean a GSM/GPRS based control system which can monitor and wirelessly update all the different performance parameters as defined to the NREDCAP in real time as per the time intervals defined by NREDCAP.

“BID/BID Documents” shall mean the BID document issued by Authorized Representative with all attachments vide BID No. NREDCAP/EV/H&M/17-106/945/2021-22 Dated: 31.03.2022

BID for supply of 945 Numbers of Electric 2- Wheelers to Health Medical & Family Welfare Department, Mangalagiri, Guntur District

for “Selection of Supplier for supply of 945 numbers of Electric 2- Wheelers Health Medical & Family Welfare Department, Mangalagiri, Guntur District and maintenance for a period of 5 years.

“**Scheduled Date of Commissioning (SDOC)**” shall mean the date which is 60 (Sixty) days from the date of issue of LOA to the Developer, on which date the OEM/Manufacturer is required to supply Electric 2- Wheelers in accordance with the provisions of the Agreement.

“**Successful Bidder**” shall mean the Bidder selected pursuant to this BID to supply and maintain the Electric 2- Wheelers for a period of 5 years as per the provisions of this BID.

“**Technical Bid**” shall mean the documents and formats as specified in Clause 5.2(d) of the BID to meet the Technical Eligibility Criteria.

“**Technical Eligibility Criteria**” shall mean provisions of Clause 5.2 (d)-of this BID.

“**Agreement**” shall mean the Agreement signed with the Successful Bidder by New& Renewable Energy Development Corporation of Andhra Pradesh Limited (NREDCAP)

“**Ultimate Parent Company**” shall mean a Company, which owns more than fifty percent (50%) equity share holding either directly or indirectly in the Parent Company.

“**Validity of LoA**” shall be valid for a period of 60 days from date of issue of LoA. Any allocation of Electric 2- Wheelers beyond this period is subject to prior approval from Authorized Representative.

BID for supply of 945 Numbers of Electric 2- Wheelers to Health Medical & Family Welfare Department, Mangalagiri, Guntur District

3 Bid information and instructions to Bidders

3.1. Obtaining BID document & Bid Processing Fees

- a) All those interested in the BID can download the BID from the website <https://tender.approcurement.gov.in>. All information related to submission of response to this BID and the Bid shall be available at the aforementioned website.
- b) Prospective Bidders interested in participating in the Bid process are required to submit their Bids in response to this BID document along with a non-refundable Bid Processing Fee of Rs. 1,00,000/- plus 18% GST.
- c) Bidders shall provide the above non-refundable Bid Processing Fee in the form of DD payable in favor of “NREDCAP” payable at Tadepalli, Guntur district. Any Bidder will be eligible to participate in the Bid process only up on submission of Bid Processing Fee at the address of the Authorized Representative as per the timelines specified in Clause 3.2 of the BID.
- d) Notwithstanding anything to the contrary contained in this BID, the Authorized Representative shall open the Technical Bid of the Bidder, only upon receipt of the above non-refundable Bid Processing Fee, along with the Covering Letter as per Format –I within the timelines mentioned in Clause 3.2 of the BID. Bidders shall also upload scanned copies of the original EMD and the DD towards Bid Processing Fee on the e Procurement platform under the PQ Check.

3.2. Timelines for Bid process

The Bidders shall submit their Bids based on the conditions specified in this BID document. The last date for submission of Bids i.e., Bid Deadline is given in the table below. No Bid shall be accepted beyond the Bid Deadline.

Sl. No	Description	
1	Department Name	New & Renewable Energy Development Corporation of AP Ltd (NREDCAP)
2	Office	The VC & Managing Director, NREDCAP
3	Tender Number	NREDCAP/EV/H&M/17-106/945/2021-22 Dated 31/03/2022
4	Tender Subject	Supply of High Speed Two Wheeler Electric Vehicles as per the delivery schedule enclosed at Annexure No C

BID for supply of 945 Numbers of Electric 2- Wheelers to Health Medical & Family Welfare Department, Mangalagiri, Guntur District

5	Tender Type	Open tender
6	Tender Category	Competitive bidding procurement from Electric Two wheeler Manufacturers.
7	Definitions and Interpretations	<p>For the purpose of e-Procurement, the following definitions shall apply</p> <ul style="list-style-type: none"> • Tender Inviting Authority shall mean the same as Authorized Representative. • Tender Documents shall mean the same as the Bid document. • “Commercial Bid” or “Price Bid” shall mean the same as the Financial Bid. • Bidders shall also upload a checklist of all documents enclosed under Technical Bid and Financial Bid and format as required under the Bid document. • “EMD/Bid Security” shall mean the same as the EMD as per the provisions of this Bid document. • Bidder/Tenderer/Contractor shall mean one and the same.
8	Tender Validity Period	90 Days from the Bid deadline date
9	Bid Security/EMD	<p>As specified in the Bid document as per the prescribed Format, proposals would need to be accompanied by a Bid Security in Indian Rupees for an amount of Rs. 25.00 lakhs and valid upto 90 days from the bid deadline.</p> <p>The bid security shall be kept valid throughout the proposal validity Period including any extensions in the proposal validity period and would be required to be further extended if so required by NREDCAP.</p> <p>Any extension of the validity of the Bid Security as requested by NREDCAP shall be provided by the agency a minimum of seven calendar days prior to the expiry of the validity of the Bid Security, being extended.</p>

BID for supply of 945 Numbers of Electric 2- Wheelers to Health Medical & Family Welfare Department, Mangalagiri, Guntur District

10	Bid Security/EMD payable to	Vice-Chairman & Managing Director, NREDCAP, Tadepalli
11	Transaction Fee	<p>All the participating bidders who submit the bids have to pay an amount of INR10,000/- & applicable service tax an amount specified by APTS and as levied by the Govt. of India on transaction fee through online in favour of MD APTS. The amount payable to the MD, APTS is non-refundable.</p> <p>Bid Processing Fee: The Tenderer shall pay an amount of INR 1,00,000 plus GST 18% (or as in force) by way of Demand Draft in favour of NREDCAP, payable at Tadepalli. The copy of the DD shall be uploaded and the original DD shall be furnished along with the tender document to NREDCAP.</p>
12	Transaction Fee/ Payable to	Payable to the MD, APTS, Vijayawada, through online payment only.
13	Bid Processing Fee	Payable to VC & MD, NREDCAP, Tadepalli by way of Demand Draft
14	Bid Document Download Start Date	31.03.2022 from 19.00 Hours
15	Bid Document Download End Date	18.04.2022 up to 11.00 Hours
16	Bid closing date	18.04.2022 before 15.00 Hours for uploading technical Bid and Financial-Bid
17	End date for submission of hard copies of Technical bid (scanned) with supporting documents	19.04.2022 before 15.00 Hours
18	Pre-Qualification Stage Opening Date	21.04.2022, at 15:00 Hours
19	Commercial Stage Opening Date	22.04.2022, at 15:00 Hours
20	Technical Qualification (TQ) Stage Opening Date	27.04.2022, at 11:00 Hours

BID for supply of 945 Numbers of Electric 2- Wheelers to Health Medical & Family Welfare Department, Mangalagiri, Guntur District

21	Reverse E-Auction start date & time	Will be intimated to the technically qualified bidders in advance by notifying in the NREDCAP/E - Procurement website.
22	Place of Tender Opening	12-464/5/1, River Oaks Apartment, CSR Kalyana Mandapam Road, Tadepalli, Guntur District, Andhra Pradesh – 522 501.
23	Contact officer	The VC & Managing Director, NREDCAP, Tadepalli
24	Address/E-mail id	gmtech@nredcap.in , ev@nredcap.in
25	Contact Details/Telephone,	Telephone – 0863 -2347650 /651/652/653
26	Procedure for Bid submission	The Bidder shall submit his response through Bid submission to the tender on e-Procurement platform at https://tender.apecurement.gov.in by following the procedure. The Bidder would be required to register on the e-procurement market place https://tender.apecurement.gov.in and submit their Bids online. Offline Bids shall not be entertained by the Tender Inviting Authority for the tenders published in e-Procurement platform.
		The Bidders shall submit their eligibility and qualification details, EMD, Technical Bid, Financial Bid etc., in the online standard formats displayed in e-Procurement web site. The Bidders shall upload the scanned copies of all the relevant certificates, documents etc., in support of their eligibility criteria/Technical Bid/EMD and other certificate/documents in the e-Procurement web site.
		The Bidder shall sign on the statements, documents, certificates, uploaded by him, owning responsibility for their correctness/authenticity.
		The Bidder shall upload the entire required documents specific to the Bid document in the e-tender platform duly signing each and every document. The bidder shall invariably submit the hard copies of the Technical bid to the Authorized Representative either personally or through courier or post before the timelines as indicated in this tender document. Non-submission of Technical bid along with relevant documents shall lead to rejection of tender.
27	Registration with e-Procurement platform	For registration and online Bid submission, Bidders may contact Procurement platform. HELP DESK of Vupadhi Techno Services Pvt. Ltd, Flat No:407, 4th Floor, Sreeram'sSneha Avenue, Near Aravinda School, Kunchanpalli, Tadepalli Mandal, Guntur district-522501. Phone: 08645-243670/71/72/73/74
		https://tender.apecurement.gov.in .

BID for supply of 945 Numbers of Electric 2- Wheelers to Health Medical & Family Welfare Department, Mangalagiri, Guntur District

		<p>1. Digital Certificate authentication: The Bidder shall authenticate the bid with his Digital Certificate for submitting the Bid electronically on e-Procurement platform and the Bids not authenticated by Digital Certificate of the Bidder will not be accepted on the e-Procurement platform. (or) Any other Registration Authority in India. The City-wise list of RAs is available by clicking the link “Apply for a Class-2 Certificate” under “Enroll” section in the web site: www.tcs-ca.tcs.co.in/mca21/index.jsp”</p> <p>2. Hard Copies: <u>Bidders shall submit hard copies of EMD and Bid Processing fee to the address mentioned in the respective clause of this Bid document before tender dead line.</u></p> <p>Bidders shall also upload scanned copies of these documents (DD/PO towards processing fee and EMD) as a part of the Qualification criteria of bid on the e-Procurement platform.</p>
		<p>All the Bidders shall invariably upload the scanned copies of DD/BG/PO in e-procurement system and this will be one of the key requirements to consider the bid responsive.</p> <p>The Authorized Representative will not take any responsibility for any delay in receipt/non-receipt of original, Certificates/Documents from the successful Bidder before the stipulated time. On receipt of documents, the department shall ensure the genuinity of certificates/documents uploaded by the Bidder in e-Procurement system, in support of the qualification criteria before concluding the agreement.</p> <p>3. GO. Ms. No. 174 -I&CAD dated: 1-9-2008:</p> <p>i. Deactivation of Bidders: If any successful Bidder fails to submit the original hard copies of uploaded certificates/documents, within stipulated time or if any variation is noticed between the uploaded documents and the hardcopies submitted by the Bidder, the successful Bidder will be suspended from participating in the tenders on e-Procurement platform for a period of 3years.</p> <p>ii. The e-Procurement system would deactivate the user ID of such defaulting Bidder based on the trigger/recommendation by the Authorized Representative in the system.</p> <p>iii. Besides this, the Authorized Representative shall</p>

BID for supply of 945 Numbers of Electric 2- Wheelers to Health Medical & Family Welfare Department, Mangalagiri, Guntur District

		<p>invoke all processes of law including criminal prosecution of such defaulting Bidder as an act of extreme deterrence to avoid delays in the Bid process for execution of the development schemes taken up by the NREDCAP. Other conditions as per the Bid document are applicable.</p> <p>iv. The Bidder is requested to get a confirmed acknowledgement from the Authorized Representative a proof of Original Hard copies submission to avoid any discrepancy.</p> <p>4. Bid document:</p> <p>i. The Bidder is requested to download the Bid document and read all the terms and conditions mentioned in the Bid document and seek</p>
		<p>Clarification if any from the Authorized Representative. <u>Any offline Bid submission clause in this Bid document could be neglected.</u></p> <p>ii. The Bidder has to keep track of any changes by viewing the Addendum/ Corrigenda issued by the Authorized Representative on time-to-time basis in the e-procurement platform. The Authorized Representative inviting Bids shall not be responsible for any claims/problems arising out of this.</p> <p>5. Bid Submission Acknowledgement:</p> <p>The Bidder shall complete all the processes and steps required for Bid submission. The system will generate an acknowledgement with a unique Bid submission number after completing all the prescribed steps and processes by the Bidder.</p> <p>Users/Bidders may also note that the Bids for which an acknowledgement is not generated by the e- Procurement system are treated as invalid or not saved in the system. Such invalid Bids are not made available to the Authorized Representative for processing the Bids. The NREDCAP, Government of AP and Vupadhi Techno Services Pvt. Ltd are not responsible for incomplete Bid submission by the Bidders/users.</p>
28	Rights reserved with the department	Authorized Representative reserves the right to Accept or reject any or all of the tenders received without assigning any reasons thereof.
29	General Terms and Conditions	As per the Bid Documents.

BID for supply of 945 Numbers of Electric 2- Wheelers to Health Medical & Family Welfare Department, Mangalagiri, Guntur District

30	Other information	<p>Bidders shall contact Vupadhi Techno Services Pvt. Ltd for all queries related to bid submission on the e-Procurement platform.</p> <p>HELP DESK of Vupadhi Techno Services Pvt. Ltd, Flat No:407, 4th Floor, Sreeram'sSneha Avenue, Near Aravinda School, Kunchanpalli, Tadepalli Mandal, Guntur District-522501.</p> <p>Phone: 08645-243670/71/72/73/74</p>
31	E-Procurement Conditions	<ol style="list-style-type: none"> 1. We, the undersigned, examined the Conditions of Contract, Specification, Special Conditions of Contract, Basic Parameters of the proposed Scheme and subsequent Addendums for the above mentioned works. We have examined, understood and checked these documents and have ascertained that there is no ambiguity in the Procurer's requirements. We accordingly offer to complete the work in conformity with such documents for the price as given in the Financial Bid submitted and attached at the commercial stage. 2. Note: Financial Bid attached at commercial stage will be considered for commercial evaluation. 3. As per the conditions in the folder management, we have extracted the file uploaded and verified the contents of the Zipped files to avoid disqualifications. 4. We have also read the Note in the folder management; the documents attached to the commercial bid stage will be encrypted and stored. Documents uploaded in Common folder and attached to the technical bid stage shall not be Encrypted.
32	Uploading	<ol style="list-style-type: none"> 1. Financial Bid shall be uploaded at the commercial stage available on the e-Procurement platform which has an encryption facility. 2. The Bidder SHALL AVOID zipping two versions of the same Financial Bid into a single folder. 3. In case the Authorized Representative finds multiple versions of the same Financial Bid in a single zip folder, such Bids are liable for rejection by the Authorized Representative.

4. Information pertaining to Bid submission via e Procurement platform

Please visit <https://tender.apecurement.gov.in> for details regarding online submission of the BID. Bidders are required to procure a Digital Signature Certificate (DSC) from any Certifying Authorities (CA) in India from the list mentioned in the below URL:

<https://tender.apecurement.gov.in/DigitalCertificate/signature.html>

The DSC is mandatory for participation in e Procurement process. The Bids can be submitted only upon logging-in with the DSC in the e Procurement portal. The Bidder would be required to register on the e-Procurement marketplace www.apecurement.gov.in or <https://tender.apecurement.gov.in> and submit their bids online. Offline Bids shall not be entertained for the tenders published in the e-Procurement platform.

The Bidders shall submit their eligibility and qualification details, technical bid, financial bid etc., in the standard formats displayed in e Procurement web site. The Bidders shall upload the scanned copies of all the relevant certificates, documents etc., in support of their eligibility criteria/Technical Bids and other certificate/documents in the e Procurement web site. The Bidder shall sign on the statements, documents, certificates, uploaded by him, owning responsibility for their correctness/authenticity.

5. Project Scope

New and Renewable Energy Development Corporation of A.P.Ltd .(NREDCAP) intend to select OEMs for supply of 945 numbers of Electric 2 – Wheelers with carriage box and maintained for a period of 5 years and deliver as per the list of delivery destinations attached of Health Medical & Family Welfare Department, Government of Andhra Pradesh Mangalagiri. The Electric 2- Wheelers complying with standards and specifications approved for type and model from any designated labs such as ARAI/ICAT/CIRT/ under CMVR Rules applicable with the following requirements,

1. The range must be 80 KMs and above.
2. Battery must be advanced chemical batteries of lithium ion or lithium phosphate or any other Lithium family with IOT to monitor the battery health status, cycles and temperature.
3. Vehicle and Battery warranty should be 5 years/50,000KMs whichever is earlier with CAN protection.
4. Carriage Box shall contains 2 inner boxes fastened tightly with outer box with top opening and lock and key and the box must be fiber reinforced plastic as per the drawing enclosed suited and fastened to the vehicle. Drawing of carriage box is indicative and minimum size and also suits the vehicle.
5. Charger to charge the vehicle as per standards and specifications of MoP /DISCOMs/ARAI and guarantee/warranty for a period of 5 years.
6. The successful bidder shall impart training to the employees after delivering the vehicles to Health Medical & Family Welfare Department about procedure for driving of E- 2 Wheeler, charging, operation and maintenance of Electric 2- Wheeler and create awareness about benefits of Electric 2- Wheeler.
7. The vehicles shall be extended 5 years AMC including one year road side assistance as per service level agreement attached at Annexure-B.
8. All relevant documents, related certificates for vehicles registration purpose shall be provided and arrange registration of the vehicle with A.P road transport authority
9. The user manual and warranty/guarantee cards shall be provided
10. The bidder will be selected based on the prequalification, technical qualification criteria and lowest price per vehicle. NREDCAP will charge 3.54 % as service charge on cost of E- 2 Wheelers including GST.
11. The bidder shall submit security deposit by way of DD/ Bank Guarantee for total amount of Rs. 25,00,000/- towards EMD in favour of NREDCAP.

12. Interested bidders fulfilling the eligibility criteria shall submit **three separate sealed tender documents for Pre-qualification Bid, Technical Bid and Commercial Bid in the formats are to be uploaded enclosed and uploaded on or before 15:00 hours on 18.04.2022 and hard copies to be submitted on or before 19.04.2022 at 15.00 Hours including Earnest Money Deposit (EMD) of Rs. 25,00,000/- (Rupees Twenty Five Lakhs Only)** and relevant processing fee in the form of DD/RTGS from any national bank drawn in favor of NREDCAP. Sealed documents shall be super scribed with **“Tender for Supply and Maintenance of 945 numbers of electric 2- Wheelers with Carriage box”** submitted to New and Renewable Energy Development Corporation of A.P Ltd (NREDCAP), 12-464/5/1, River Oaks Apartments, CSR Kalyana Mandapam Road, Tadepalli, Guntur District- 522 501.

Bid Validity period and Extension of Proposal Validity period

The Bidder shall submit its Bid in response to Bid document which shall remain valid up to Ninety (90) days from the Bid Deadline (“Bid Validity”). Authorized Representative reserves the right to reject Bid which does not meet the validity requirement.

In exceptional circumstances, prior to expiry of the original Proposed Validity Period, NREDCAP may request the Bidders to extend the period of validity for a specified additional period. The request and the Bidders’ responses shall be made in writing. NREDCAP reserves the right to reject the Proposal submitted by any Bidder who fails to extend the period of validity of its Proposal in line with the provisions of this clause.

The Bid Validity Period of the Successful Bidder shall be automatically extended till the date on which the Agreement is signed and is in force.

5.1. Qualification Requirements

Evaluation of Bids will be based on meeting the technical and financial qualification requirements. Any Bidder who meets the Qualification Requirements stated herein shall be “Qualified Bidder” for the purpose of evaluation under this Bid document.

Eligibility criteria:

(i) BIDDER:

The Bidder should be a Public limited company or Private limited company or Consortium. The company /companies should be registered in India. The term ‘Bidder’ used hereinafter would therefore apply to both a single Bidder and/ or the Consortium.

The Bid submitted by a Consortium should comply with the following additional requirements failing which shall result in disqualification.

- Number of members in a Consortium should be limited to three (3).
- The Bid should contain the information required for each member of the Consortium
- Each Consortium must nominate a lead member/prime bidder of the Consortium and must submit the Power of Attorney by all members of the

BID for supply of 945 Numbers of Electric 2- Wheelers to Health Medical & Family Welfare Department, Mangalagiri, Guntur District

Consortium in favour of the lead member/prime bidder.

- Any Company applying as a sole Bidder cannot at the same time be member of any Consortium applying for this Project. Further, a member of a particular Consortium cannot be member of any other Consortium applying for this Project. Any Bidder who submits or participates in more than one Bid for this Project will be disqualified and will also lead to disqualification of the Consortium of which it is a member.
- Members of the Consortium shall enter into a Memorandum of Understanding (MoU) specific to this Project which shall be submitted with the Tender document. The MoU shall, inter alia:
 - Convey the intent to form a Consortium, with commitments in accordance with the Tender Document, which would enter into the Project Agreement and subsequently carry out all the responsibilities as Implementing Agency in terms of the Project Agreement, in case the Project is awarded to the Consortium.
 - Clearly outline the proposed roles and responsibilities of each member at each stage.

The members of the Consortium shall be jointly liable for the execution of the Project in accordance with the terms of the tender document; however, NREDCAP will interact with lead member who shall own all liability and responsibility on behalf of consortium.

The Consortium as a whole must be a sound entity both technically and financially.

The change in composition of the Consortium (i.e. Insertion or deletion of new/existing members) will not be allowed after the submission of the Bid.

- (ii) The company shall be in the field of Electrical Vehicle/ICE Vehicles/Energy Storage/Battery Manufacturing for at least 3 years. In the case of consortium of companies, the lead member shall fulfill this criterion.
- (iii) The Company or consortium Group cumulative annual turnover of at least INR 50 crores during the last three (3) financial years ending with March 2022 duly certified by the Chartered Accountant/ Audited Accounts.
- (iv) The company should have sold 2000 numbers of vehicles during the last three years or till the last date of bid-submission date and submit relevant certificate from practicing Auditor.
- (vi) The company should have dealer network in 10 locations in Andhra Pradesh
- (vii) The company/consortium groups should not have been black listed/debarred /disqualified by any Govt. Entity or any International Agency for non- delivery or noncompliance or corrupt/fraudulent practices. The company should give self-declaration to this effect and the onus will be on the applicant.

5.2. Bid Submission

a) Pre-qualification Check i.e. Technical eligibility and financial eligibility criteria

(Mandatory for all the Bidders)

- i. Covering Letter corresponding to Prequalification Bid as per Format I of this BID.
- ii. Legible scanned copies of EMD and Bid Processing Fee shall be uploaded in accordance with this BID and as per timelines specified in the BID.
- iii. Certificate from designated labs for type and model approval of E- 2 Wheelers with carriage box.
- iv. Proof of supply of vehicles from practicing Chartered Accountants for sale of 2000 numbers of two wheelers during last 3 years.
- v. The Electric 2- Wheelers batteries shall be warranted for a minimum period of 5 Years/50,000 KMs whichever is earlier from the date of delivery.
- vi. The Prices indicated in the purchase order are inclusive of all taxes, insurance for 5 years, registration charges, AMC for 5 years, transportation to the list of delivery destinations of Health and Medical Department enclosed at Annexure C.
- vii. Cumulative Turnover during last 3 years, FY 2019-20, FY 2020-21, FY 2021-22 shall be at least INR 50crore in the field of Automotive Field/Energy Storage/ Electric Vehicles Manufacturing activity.
- viii. Copies of audited financial statements along with a certificate from Chartered Accountant/Statutory Auditor, as applicable, confirming the Cumulative Turnover. Provisional financial statements certified by chartered accountant shall be furnished. For Bidding Firms, copies of Income Tax returns with full details of turnover should be furnished along with a certificate from the CA confirming the Cumulative Annual Turnover and net worth.

b) General Criteria

- i. Any Bidder including its Associate Company /Parent Company /Ultimate Parent Company cannot submit more than one Bid under this BID.’
- ii. Bidder can use the technical strength of its Associate Company /Parent Company/Ultimate Parent Company to fulfill the Technical Eligibility criteria mentioned. In such case, Bidders shall submit a certificate of relationship of Associate Company/Parent Company/ Ultimate Parent Company with the Bidding Company as per Format. Company Secretary Certificate towards such share holding pattern along with a Board resolution shall be submitted.

iii. Foreign companies are not eligible to participate in this Bid process.

Bidders in Conflict of Interest with one another shall be liable for disqualification /rejection under the sole discretion of the Authorized Representative. Bidder shall make relevant disclosures.

c) Memorandum of Understanding Of Consortium Partners:

Members of the Consortium shall submit a Memorandum of Understanding (MoU) for the purpose of submitting the Proposal. The Memorandum of Understanding (MoU) shall be furnished on a non-judicial stamp paper of Rs. 100/-, duly attested by notary public.

The MoU shall, inter alia:

Convey the intent to form a Special Purpose Vehicle with shareholding commitment(s) explicitly stated.

The MoU shall communicate the willingness of the Consortium to subsequently carry out all the responsibilities as in terms of the Agreement, in case the Project is awarded to the Consortium.

Clearly outline the proposed roles and responsibilities of each member at each stage.

Clearly state those members of the Consortium shall be liable jointly for the execution of the Project in accordance with the terms of the Agreement and a statement to this effect shall be included in the MoU.

Should be accompanied by the Board Resolutions (in case of corporate members) and/or undertakings (in case of individual members) of the Consortium, giving authority/undertaking to enter into an MoU with other members for undertaking the Project and, if successful, to participate and undertake the Project and in case of corporate members nominating and authorizing an authorized representative of the member to sign and enter into the MoU and execute Power of Attorneys for the Project.

Should be accompanied by a certified true copy of the Memorandum and Articles of Association (in case of corporate members) and registration number/PAN/TAN/GST.

A copy of the MoU duly notarized, should be submitted along with the Proposal. The MoU entered into among the members of the Consortium should be specific to this Project and should contain the above requirements failing which; the Application shall be rejected as non-responsive. The MoU should be governed by the laws, rules and regulations of India and should be subject to jurisdiction of Indian Courts only.

The Proposal shall be signed by the duly authorized signatory of the Lead Member and shall be legally binding on all the members of the Consortium.

BID for supply of 945 Numbers of Electric 2- Wheelers to Health Medical & Family Welfare Department, Mangalagiri, Guntur District

All witnesses and sureties shall be persons of status and probity and their full names, addresses and telephone numbers/mobile numbers shall be stated below their signature. All signatures in the Proposal documents shall be dated.

d. Technical Eligibility Criteria

- i. The model and type approval from accredited labs under CMVR to the E-2 Wheeler vehicle shall be submitted for high speed vehicle for 80 KMs range per charge.
- ii. The vehicle shall be Fame-II compliance and with 100% local content
- iii. The bidder should have manufacturing experience in Automobile components/Motor Vehicles/Energy Storage/Battery Manufacturing fields for a period of three years with 50 Cr Turnover.
- iv. The Supplier/OEM should have a dealership network in ten locations with in AP

e. Financial Eligibility Criteria for Open Category

- i. Cumulative Turnover during last 3 years, FY 2019-20, FY 2020-21, FY 2021-22 shall beat least INR 50 crore in the field of Automotive field/Energy Storage/ Electric Vehicles Manufacturing/ EV Charging/Battery Swapping Infrastructure or any other related activities to EV Segment with or without JV
- ii. Copies of audited financial statements along with a certificate from Chartered Accountant/Statutory Auditor, as applicable, confirming the Cumulative Turnover. Provisional financial statements certified by chartered accountant shall be furnished. For Bidding Firms, copies of Income Tax returns with full details of turnover should be furnished along with a certificate from the CA confirming the Cumulative Annual Turnover and net worth

5.3. Financial Bid

Cost per E- 2 Wheeler to run 80KMs per charge which includes 5 years of battery and vehicle warranty or 50,000 KMs whichever is earlier, Registration charges, AMC for 5 years, training to the employees inclusive of all taxes, insurance for 5 years, transportation to delivery destinations as per list of locations belonging to attached Medical and Health Department, Mangalagiri and any other charges /taxes etc. as per the format VI.

5.4. Earnest Money Deposit (EMD) and performance Guarantee (PG)

- a) **Earnest Model Deposit:** Earnest Money Deposit (EMD) shall be INR 25,00,000 Lakh. EMD shall be in the form of a DD in favour of “NREDCAP” payable at Tadepalli, Guntur district or a Bank Guarantee with a validity of 180 days as per the Format VIII, shall be submitted by the Bidder along with the Bid, failing which the Bid shall be summarily rejected. The copy of the DD or Bank Guarantee shall be uploaded in <https://tender.apecurement.gov.in> and the original DD or Bank Guarantee shall be furnished to NREDCAP before closing date, failing which the bid shall be summarily rejected.
- b) **Performance Guarantee (PG):** Successful Bidders, selected by the NREDCAP shall submit
Successful Bidders selected shall be issued LoA and invited to sign Agreement.
Performance Guarantee of a value equal to Rs 75,00,000/- (Seventy Five Lakhs Only). The effective date till 5 years from date of LOA and successful completion of warranty period. The EMD submitted, amount Rs.25,00,000 will be returned against the receipt performance guarantee.
- c) Liquidated Damages shall be payable by OEM/ Manufacturer equivalent to 1% of value of allocated Electric 2- Wheeler to each week subject to maximum of 4 weeks of delay.
- d) In case, the Electric 2- Wheelers are not supplied even after 4 weeks from the scheduled date or extended date, the bank guarantee will be revoked.
- e) The format of the Bank Guarantee prescribed in the BID shall be strictly adhered to and any deviation from the above formats may result in rejection of the Bid. The bidder shall submit EMD for Rs. 25,00,000/- in the form of bank guarantee or demand draft/RTGS/NEFT
- f) The Bank Guarantees shall be executed on non-judicial stamp paper of appropriate value as per AP Stamp duties Act relevant to the place of execution. The Bank Guarantees have to be in the name of the Bidding Company/ Bidding Firm.
- g) All expenditure towards execution of Bank Guarantees such as stamp duty etc. shall be borne by the Bidders.
- h) NREDCAP shall release the EMD of the unsuccessful Bidders within ten (10) days of issuing Letter of Award (LoA) to the Successful Bidders.

5.5. Payment Terms

- a) The OEM/Manufacturer shall submit the invoice in the name of VC& Managing Director, NREDCAP, Tadepalli.

Upon successful supply of 945 numbers of E- 2 Wheelers with in 60 days from the date of award of and 90% of the Invoice amount will be released on submission of the certified bills from the user organization and District Manager, NREDCAP concern district and other documents such as registration, AMC and insurance etc., Balance 10% of the invoice amount will be made against Bank guarantee or after completion of One (1) year period for the vehicle and the performance guarantee 75 Lakhs will be released after successful completion of the AMC period of 5 years.

- b) The amount will be released duly deducting applicable taxes and NREDCAP service charges @ 3.54 %including GST.
- c) The OEM/Manufacturer shall be responsible for submitting original invoice along with relevant documents to the NREDCAP office by Registered Postor by hand with necessary certifications from user organization and District Managers, NREDCAP.

5.6. Clarifications/Pre-Bid meeting/Enquires/Amendments

Clarifications / Doubts, if any, on BID document shall be e-mailed to gmtech@nredcap.in(or) ev@nredcap.in. Bidders are requested to remain updated with the website www.nredcap.in. If necessary, amendments shall be issued by Authorized Representative which will be notified in the e Procurement website/NREDCAP official website www.nredcap.in. No separate reply/intimation will be given for the above, elsewhere.

5.7. Fraudulent and Corrupt Practices

- a) The Bidders and their respective officers, employees, agents and advisers shall observe the highest standard of ethics during the Bid process and subsequent to the issue of the LoA. Notwithstanding anything to the contrary contained herein, or in the LoA, the Authorized Representative shall reject a Bid, withdraw the LoA, as the case may be, without being liable in any manner whatever to the Bidder, if it determines that the Bidder has, directly or indirectly or through an agent, engaged in corrupt practice, fraudulent practice, corrective practice, undesirable practice or

BID for supply of 945 Numbers of Electric 2- Wheelers to Health Medical & Family Welfare Department, Mangalagiri, Guntur District

restrictive practice in the Bid process. In such an event, the Authorized Representative shall forfeit the EMD, without prejudice to any other right or remedy that may be available to the Authorized Representative here under or otherwise.

- b) Without prejudice to the rights of the Authorized Representative and the rights and remedies which the Authorized Representative may have under the LoA, if a Bidder is found by the Authorized Representative to have directly or indirectly or through an agent, engaged or indulged in any corrupt practice, fraudulent practice, coercive practice, undesirable practice or restrictive practice during the Bid process, or after the issue of the LoA or after signing of Agreement, such Bidder shall be blacklisted and shall not be eligible to participate in any tender or BID issued by the Authorized Representative, during a period of three (3) years from the date such Bidder is found by the Authorized Representative to have directly or indirectly or through an agent, engaged or indulged in any corrupt practice, fraudulent practice, coercive practice, undesirable practice or restrictive practices, as the case maybe.
- c) The following terms shall have the meaning here in after respectively assigned to them:
- i. **“Corrupt Practice”** means (i) the offering, giving, receiving, or soliciting, directly or indirectly, of anything of value to influence the actions of any person connected with the Bid process (for avoidance of doubt, offering of employment to or employing or engaging in any manner whatsoever, directly or indirectly, any official of the authorized representative who is or has been associated or dealt in any manner, directly or indirectly with the Bid process or the LoA or has dealt with matters concerning the Agreement or arising there from, before or after the execution thereof, at any time prior to the expiry of one year from the date such official resigns or retires from or otherwise ceases to be in the service of the Authorized Representative, shall be deemed to constitute influencing the actions of a person connected with the Bid Process); or (ii) engaging in any manner whatsoever, whether during the Bid Process or after the issue of the LoA or after signing of the Agreement, as the case maybe, any person in respect of any matter relating to the project or the LoA or the Agreement, who at any time has been or is a legal, financial or technical adviser of the Authorized Representative in relation to any matter concerning the Project;
 - ii. **“Fraudulent Practice”** means amis representation or omission of facts or suppression of facts or disclosure of incomplete facts, in order to influence the Bid process.

BID for supply of 945 Numbers of Electric 2- Wheelers to Health Medical & Family Welfare Department, Mangalagiri, Guntur District

- iii. **“Coercive Practice”** means impairing or harming, or threatening to impair or harm, directly or indirectly, any person or property to influence any persons participation or action in the Bid process.
- iv. **“Undesirable Practice”** means (i) establishing contact with any person connected with or employed or engaged by the Authorized Representative with the objective of canvassing, lobbying or in any manner influencing or attempting to influence the Bid process; or (ii) having a Conflict of Interest; and
- v. **“Restrictive Practice”** means forming a cartel or arriving at any understanding or arrangement among Bidders with the objective of restricting or manipulating a full and fair competition in the Bid process.

5.8.E-Auction (Reverse Tendering)

After identifying the eligible agencies/bidders will be eligible to participate in e-auction process in terms of guidelines issued vide G.O.Ms .No.67 (WR) (Reforms) Dt: 16.08.2019.

- a) All bidders shall furnish the original hard copies of the BG for EMD within the stipulated time. Failing which their Initial Price Offer shall not be opened and they will not be taken forward into the reverse auction.
- b) To conduct the reverse tender process at least two bidders would be required.
- c) Names of the bidders /Vendors shall be anonymously masked in the Reverse Tendering process and vendors will be given suitable dummy names.
- d) After identification of the L-1 Initial Price Offer, eligible (those who have submitted original hard copies of the BG for EMD within the stipulated time) bidders shall be transferred to the Reverse Auction Platform.
- e) The L-1 price offer (Initial) shall be maximum allowable Bid Price for the reverse tendering process.
- f) Only one round of reverse tendering shall be carried out in which bidders can revise their bids multiple times within the time limits specified.
- g) At the start of the Reverse Tendering process the Maximum Allowable Bid Price will be set and bidders shall submit their bids in an online platform.
- h) The initial period of the Reverse Tendering process will start after 3 hours, following which there will be auto extensions of time by 15 minutes in case of any reduction in bids recorded in the prior 15 minutes.
- i) Only the current L-1 Bid shall be visible to all bidders who may revise their bids until the end of the process.
- j) Decrements made in each subsequent bid shall not be less than 0.5% of the ECV uploaded.
- k) The L-1 bid may be determined following a period of inactivity of more than 15 minutes of reverse bidding after the initial 3-hour period after closure of the main bidding.

BID for supply of 945 Numbers of Electric 2- Wheelers to Health Medical & Family Welfare Department, Mangalagiri, Guntur District

- l) Following the determined following a period of the L-1 bid, the L-1 Bidder's supporting tendering process shall be on hold for a maximum period of 24 hours (1 day) while the L-1 bidder's supporting documents are verified.
- m) Not with standing anything explained above, the condition explained in G.O.Ms.No.67 Water Resources (Reforms) Dept, Dated: 16.08.2019 will hold good.

5.9. CONCLUSION OF REVERSE TENDERING PROCESS:

- a) After conclusion of the reverse auction process, the pre-qualification criteria of all bidders shall be verified for the successful bidder. In case of successful verification of pre-qualification criteria of the L-1 Bidder, he will be awarded the contract and the EMDs of other successfully verified bidders shall be refunded.
- b) If any variation is noticed between the uploaded documents and the self-declaration submitted by the bidder, the bidder will be suspended from participating in the tenders on e-procurement platform for a period of 3 years. If any of the documents furnished by the bidder are found to be false/fabricated/Bogus, at any time the bidder will be black listed and the EMD will be forfeited.
- c) In case of the L1 bidder being disqualified, the Department reserves the right to restart the reverse auction process with the L2 Price of the concluded reverse auction as the start/maximum bid price OR to restart the entire tendering process from the NIT stage. In either case, the date and the time of the subsequent process shall be communicated to the remaining bidders.

5.10. Other Provisions

Power to Remove Difficulties

If any difficulty arises in giving effect to any provision of the BID guidelines or interpretation of the BID guidelines or there is a requirement to modify the BID guidelines for better implementation, the matter may be considered by the Authorized Representative for this purpose and its decision will be final.

5.11. Indemnity

Selected bidder will indemnify the NREDCAP and Health Department to defend and hold harmless each other and its divisions, successors, subsidiaries and affiliates, the assigned of each and their directors, officers, agents and employees from and against all liabilities, claims, losses, and damages of any nature, including, without limitation, all expenses (including attorney's fees), cost, and judgments incident there to NREDCAP and NREDCAP obligations under this indemnity will survive the expiration, termination, completion or cancellation of this Contractor an order hereunder.

6. Formats

Formats for Bid Submission

The following formats are required to be submitted as part of the BID. These formats are designed to demonstrate the Bidder's compliance with the Qualification Requirements set forth and other submission requirements specified in the BID.

- i. Format for prequalification check (Format I)
- ii. Format of Covering Letter (Format II)
- iii. Format for Power of Attorney to be provided by Bidding Company in favor of Authorized signatory (Format III)
- iv. Format for Technical Eligibility Criteria (Format IV)
- v. Format for Financial Eligibility Criteria (Format V)
- vi. Formats for submission of Financial Bid (Formats VI)
- vii. Format for Bank Guarantee (Format VII)
- viii. Declaration regarding "Restrictions on procurement from a Bidder of a country which shares a land border with India" (Format- VIII)
- ix. Certificate Regarding Declaration of Local Content (Format- IX)
- x. Litigation History (Format – X)

The Bidder may use additional sheets to submit the information for detailed response.

BID for supply of 945 Numbers of Electric 2- Wheelers to Health Medical & Family Welfare Department, Mangalagiri, Guntur District

Format-I: Covering Letter to Prequalification check

(The covering letter should be on the Letter Head of the Bidding Company/Bidding Firm)

Date: _____

Reference No: _____

From: _____ (Insert name and address of Bidding Company/Bidding Firm)

Telephone Number:

Fax:

E-mail address:

To

The VC & Managing Director, NREDCAP12-464/5/1, River Oaks Apartments,
CSR Kalyana Mandapam Road, Tadepalli, Guntur District-522501,

Sub: Response to BID No dated [Insert date in dd /mm/yyyy for supply of 945 numbers of E- 2 Wheelers.

-----0-----

Dear Sir,

I/We, the undersigned[insert name of the 'Bidder'] having read, examined and understood in detail the BID including Qualification Requirements in particular, terms and conditions of the Agreement, here by submit my/our Bid in response to BID.

I/We have uploaded scanned copies of the original documents on the website specified by the Authorized Representative, and I/We are here by submitting the original documents as specified.

Table A: Details pertaining to EMD

S No	EMD through BG			EMD through DD		
	BG Value in INR	Ref No.	Validity Date	DD Amount	DD No.	DD Date
1						

Table B: Details pertaining to Bid Processing Fee

S No	DD Amount	DD No.	DD Date

- i. Certificate from designated labs for type and model approval to Electric 2- Wheelers.
- ii. Proof of supply of 2000 vehicles with certificate from chartered accountants.
- iii. AP Government Transport Department registration certificates if any.
- iv. The Electric 2- Wheelers with batteries shall be warranted for a minimum period of 5 Years from the date of delivery OR 50,000KMs whichever earlier.
- v. Financial Eligibility is 50 crore for the financial years 2019 to 2022 or till last date of bid submitted as per format

BID for supply of 945 Numbers of Electric 2- Wheelers to Health Medical & Family Welfare Department, Mangalagiri, Guntur District

I/We, undertake to bid for supply of 945 numbers of Electric 2- Wheelers are enclosed for which EMD mentioned above, of relevant amount in accordance with provisions under BID.

Thanking you,

Yours faithfully,
(Name, Designation and Signature of Authorized Signatory).

BID for supply of 945 Numbers of Electric 2- Wheelers to Health Medical & Family Welfare Department, Mangalagiri, Guntur District

Format-II: Covering Letter

(The covering letter should be on the Letter Head of the Bidding Company/Bidding Firm)

Date: _____ Reference No: _____

From: _____ (Insert name and address of Bidding Company/Bidding Firm)

Telephone Number:

Fax:

E-mail address:

To

The VC & Managing Director, NREDCAP12-464/5/1, River Oaks Apartments,
CSR Kalyana Mandapam Road, Tadepalli, Guntur District-522501,

Sub: Response to **BID No** _____ dated _____ [Insert
date in dd/mm/yyyy] for supply of 945 numbers of Electric 2- Wheelers.

---0---

Dear Sir,

I/We, the under signed.....[insert name of the 'Bidder']having read, examined, and understood in detail the BID including Qualification Requirements in particular, terms and conditions of the Agreement hereby submit my/our Bid in response to BID. I/We are submitting our Bid for supply of 945 numbers of Electric 2- Wheelers mentioned in Format- I submitted as part of the Bid.

1. I/We give my/our unconditional acceptance to the BID, dated.....
[Insert date in dd/mm/yyyy], standard Agreement attached there to, issued by Authorized Representative. In token of my/our acceptance to the BID, Agreement along with the amendments and clarifications issued by Authorized Representative, the same have been initialed by me /us and enclosed with the response to BID. I/We shall ensure that the Agreement is executed as per the provisions of the BID, provisions of Agreement shall be binding on me/us. Further, I/we confirm that the Electric 2 Wheelers shall be supplied within the timelines specified in this BID.
2. I/We have submitted our response to BID strictly as per provisions under Clause 6(Formats) of this BID, without any deviations, conditions and without mentioning any assumptions or notes in the said Formats.
3. I/We hereby declare that I/We are participating in this Bid process.
4. I/We hereby declared that we have read and understood the BID and the hard copy of the initialed BID shall be submitted upon finalization as Successful Bidder.
5. I/We hereby unconditionally and irrevocably agree and accept that the decision made by Authorized Representative in respect of any matter regarding or arising out of the BID shall be binding on me/us. I/We hereby expressly waive and withdraw any deviations and all claims in respect of this process.
6. I/We hereby undertake that we will comply to the technical specifications of the Electric 2- Wheelers as detailed in Annexure-A of this BID.

BID for supply of 945 Numbers of Electric 2- Wheelers to Health Medical & Family Welfare Department, Mangalagiri, Guntur District

7. I/we hereby declare that we are not in Conflict of Interest with any other Bidder in this Bid process, and we have submitted only one Bid in response to this BID and are not participating under any other Bid in this BID. I/we hereby declare that we are in compliance with provisions of the BID

8. I/We hereby undertake that the components/items to be supplied for installation of the system shall be as per the component/items indicated in the Test Certificate of the authorized test centers under CMVR.

9. Familiarity with Relevant Indian Laws & Regulations:

I/We confirm that I/we have studied the provisions of the relevant Indian laws and regulations as required to enable us to submit this response to BID, and execute the Agreement, in the event of my/our selection as Successful Bidder.

10. I/We are enclosing herewith my/our response to the BID with formats duly signed as desired by you in the BID for your consideration.

It is confirmed that my/our response to the BID is consistent with all the requirements of submission as stated in the BID and subsequent communications from Authorized Representative.

The information submitted in our response to the BID is correct to the best of my/our knowledge and understanding. I/We would be solely responsible for any errors or omissions in my/our response to the BID.

I/We (in case of a Company) confirm that the Power of Attorney has been issued to the Authorized Signatory of this Bid pursuant to the Board Resolution

.....[Insert date in dd/mm/yyyy]

I/We confirm that I/We have the necessary execution capacity to implement and execute the Electric 2- Wheelers allocated to us pursuant to our finalization as Successful Bidder after implementation of the allocation process.

11. Contact Person:

Details of the representative to be contacted by Authorized Representative are furnished as under:

Name :
Designation :
Company <if applicable>:Address :
Phone No. :

BID for supply of 945 Numbers of Electric 2- Wheelers to Health Medical & Family Welfare Department, Mangalagiri, Guntur District

Mobile No. :
Fax No. :
E-mail address :
Alternate Email address :

12. I/We have neither made any statement nor provided any information in this Bid, which to the best of my/our knowledge is materially inaccurate or misleading. Further, all the confirmations, declarations and representations made in my/our Bid are true and accurate. In case this is found to be incorrect after my/our selection as Successful Bidder, I/we agree that the same would be treated as the Bidder's event of default under Agreement and consequent provisions of Agreement shall apply.

Dated the _____ day of _____ 20...

Thanking you,

Yours faithfully,

(Name, Designation and Signature of Authorized Signatory)

Format-III: Format for Power of Attorney

(To be provided by the Bidding Company in favour of the Authorized Signatory of the Bidding Company)

POWEROFATTORNEY

(To be executed on non-judicial stamp paper of appropriate value as per Stamp Act relevant to place of execution.)

KNOW ALL MEN BY THESE PRESENTS THAT M/s..... having its registered office athaving agreed to appoint Mr/Ms....., having his/her address at.....and appointed asat the Bidding Company, as the Authorized Signatory, do here by constitute, nominate and appoint Mr/Ms.....

as our duly constituted lawful Attorney (hereinafter called as Authorized Signatory) to exercise all or any of the powers for and on behalf of the Bidding Company in regard to submission of the response to BID No We also authorize the said Authorized Signatory to undertake the following acts:

- i. To submit on Bidding Company, the response to BID.
- ii. To do any other act or submit any information and documents related to the above response to BID.

It is expressly understood that in the event of the Bidding Company being selected as Successful Bidder, this Power of Attorney shall remain valid, binding, and irrevocable until the Bidding Company achieves execution of Agreement.

We as the Directors of the Bidding Company agree and undertake to ratify and confirm all whatsoever the said Attorney/Authorized Signatory has done on behalf of the Bidding Company pursuant to this Power of Attorney and the same shall bind us and deemed to have been done by us.

IN WITNESS WHEREOF M/s, as the Director of the Bidding Company have executed these presents on this...Day of.....under the Common Seal of our Company.

For and on behalf of Bidding Company M/s.....

(Signature of person authorized by the board)

(Name Designation Place: Date:)

Accepted

BID for supply of 945 Numbers of Electric 2- Wheelers to Health Medical & Family Welfare Department, Mangalagiri, Guntur District

(Signature, Name, Designation and Address of the Authorized Signatory)

Attested

(Signature of the executant)

(Signature & stamp of Notary of the place of execution)

Place:..... Date:.....

Notes:

The mode of execution of the power of attorney should be in accordance with the procedure, if any, laid down by the applicable law and the charter documents of the executants (s) and the same should be under common seal of the executants affixed in accordance with the applicable procedure. Further, the person whose signatures are to be provided on the power of attorney shall be duly authorized by the executants (s) in this regard.

BID for supply of 945 Numbers of Electric 2- Wheelers to Health Medical & Family Welfare Department, Mangalagiri, Guntur District

Format- IV: Format for Technical Eligibility Criteria

To,

**The VC & Managing Director, NREDCAP12-464/5/1, River Oaks Apartments,
CSR Kalyana Mandapam Road, Tadepalli, Guntur District-522501**

Dear Sir,

Sub: Response to BID No. _____ for selection of OEM/ Manufacturer
for

Supply of 945 numbers of E- 2- Wheelers and maintained for a period of 5 years

----0----

I/We here by submit the details of physical experience i.e supply of E- 2 Wheelers to meet the Technical Eligibility Criteria as per the provisions of the BID.

Technical Eligibility Criteria

Sl. No.	Name of the company whose experience is being considered	Parameter	FY2019 20	FY2020- 21	FY2021 22	Total
1		2000 numbers of Electric 2- Wheelers Lithium Ion Batteries. Details of Registration number of each vehicle supplied				

I/We undertake that we are not blacklisted by any Govt. Agency in the past or at present. I/We undertake that were not black listed ever by any Govt. Agency.

Signature and seal of practicing
Chartered Accountant

BID for supply of 945 Numbers of Electric 2- Wheelers to Health Medical & Family Welfare Department, Mangalagiri, Guntur District

Format- V: Format for Financial Eligibility Criteria

To,

**The VC & Managing Director,
NREDCAP,12-464/5/1,RiverOaksApartments,
CSR Kalyana Mandapam Road,
Tadepalli-522501,GunturDistrict**

Dear Sir,

Sub: Response to BID No. for selection of OEM/Manufacturer for Selection of OEM/Manufacturer to Supply and Maintenance of 945 number of E- 2 Wheelers with lithium ion batteries.

----0----

I/We here by submit the following documents to meet the Technical Eligibility Criteria as per the provisions of the BID.

I/We here by undertake to certify that we have cumulative annual turnover of Rs. 50 Crore in supply of electric 2- Wheelers/ Auto Components/Energy Storage/Battery Manufacturing etc.,

Sl. No.	Financial year	Turnover(INR Lakhs)
1	FY2019-20	
2	FY2020-21	
3	FY2021-22	
	Cumulative Annual Turnover	

NOTE:

- i. Attach certificate from the Chartered Accountant/Statutory Auditor along with audited financial statements (Balance Sheet, Profit & Loss Account, Schedules and cash flow statement). Provisional financial statements certified by chartered accountant.
- ii. The documents submitted without certification by the Chartered Accountant shall not be considered.

Signature and seal of practicing
Chartered Accountant

BID for supply of 945 Numbers of Electric 2- Wheelers to Health Medical & Family Welfare Department, Mangalagiri, Guntur District

Format- VI :Format for Financial Bid

Name of the Bidder: _____

S No	Model	Quoted number for supply of E- 2 Wheelers	Description	Unit Rate in Rs. (Incl. Taxes) Rs- per E-2 Wheeler	Total Cost for 945 E-2 Wheelers
A	B	C	D	E	F
1		945	Supply and Maintenance of 945 Numbers of E- 2 Wheelers to with Carriage box to the list of destinations of Health Medical & Family Welfare Department, Mangalagiri including Registration charges, 5 years Insurance, Transportation, 5 years AMC and taxes if any		

Certified that:

- Above rates are in accordance with the specifications & various terms & conditions mentioned in the BID and are applicable for supply to list of locations attached belonging to Health Medical & Family Welfare Department, Mangalagiri
- The rates are inclusive of all latest prevailing taxes and duties etc., of Govt. of Andhra Pradesh as well as Govt. of India.
- The rates for supply of E- 2 Wheelers, registration and transportation charges including 5 years/50,000 KMs whichever is earlier of warranty to vehicle and batteries, insurance for 5 years, annual maintenance for a period of Five (5) years as per service level agreement enclosed etc.

Signature of Authorized Signatory of the manufacturer with seal

Place:

Date:

Format –VII: Format for Bank Guarantee

To : [name of Employer)

[Address of Employer)

Whereas_____[name and address of Developer]

(Herein after called “the Developer”) has undertaken, in pursuance of Contract No.

_____dated_ to execute_____[name of Agreement and brief description of Works] (here in after called “the Agreement”).

AND WHEREAS it has been stipulated by you in the said Agreement that the OEM/Manufacturer shall furnish you with a Bank Guarantee by a recognized bank for the sum specified therein as security for compliance with his obligations in accordance with the Agreement “

AND WHERE AS we have agreed to give the OEM/Manufacturer such a Bank Guarantee:

NOW THEREFORE we hereby affirm that we are the Guarantor and responsible to you, on behalf of the Developer, up to a total of_____[amount of guarantee] 1_____[in words], such sum being payable in the types and proportions of currencies payable as per the Agreement in which the Contract Price is payable, and we undertake to pay you, upon your first written demand and without cavil or argument, any sum or sums within the limits of

_____[Amount of guarantee] 1 as afore said without your needing to prove or to show grounds or reasons for your demand for the sum specified therein.

We hereby waive the necessity of your demanding the said debt from the OEM/Manufacturer before presenting us with the demand.

We further agree that no change or addition to or other modification of the terms of the Agreement or of the Works to be performed there under or of the Agreement documents which may be made between you and the Contract Hall in anyway release us from any liability under this guarantee, and we hereby waive notice of any such change, addition or modification.

This guarantee shall be valid until days from the Expiry Date (which shall be 180 days from Expiry Date)

Witnesses Signature and seal of the Guarantor
Name of Bank & Address ____

BID for supply of 945 Numbers of Electric 2- Wheelers to Health Medical & Family Welfare Department, Mangalagiri, Guntur District

Format -VIII: Declaration regarding “Restrictions on procurement from a Bidder of a country which shares a land border with India”

(To be submitted on Applicant’s Letter Head)

To,

**The VC & Managing Director,
NREDCAP,12-464/5/1,RiverOaksApartments,
CSR Kalyana Mandapam Road,
Tadepalli-522501,GunturDistrict**

Dear Sir,

With reference to our bid proposal for participation in NREDCAP tender NIT/Bid Document No :

_____ dated:_____,I/we here by confirm that, I/We have read the clause as mentioned in the tender document mentioned above regarding restrictions on procurement from a bidder of a country which shares a land border with India and on sub-contracting to contractors from such countries.

*Bidder to strike-off, if not applicable.

**Bidder to mention the Annexure no.

Date:_____ Signature

Place:_____

Seal of Organization &
of Authorized Applicant

BID for supply of 945 Numbers of Electric 2- Wheelers to Health Medical & Family Welfare Department, Mangalagiri, Guntur District

Format – IX: CERTIFICATE REGARDING DECLARATION OF LOCAL CONTENT

[On the Letter Head]

To,

**The VC & Managing Director,
NREDCAP, 12-464/5/1, River Oaks Apartments,
CSR Kalyana Mandapam Road,
Tadepalli-522501, Guntur District**

Sub: Compliance of Minimum Local Content Requirement as mentioned in Ministry of Commerce and Industry Trade and order no. P-45021/2/2017-PP (BE-II) dated 04th June 2020.

Ref: NIT/ Bid Document No:

---0---

Dear Sir/Madam,

This is to certify that following is the local content percentage Being offered/quoted against aforementioned tender by M/s....., the same is in compliance with Ministry of Commerce and Industry order no: **P-45021/2/2017-PP(BE-II) dated 04th June 2020** and the bidder shall strictly abide by all provisions of the subject notification.

Sr. No	Item/s	Percentage of Local Content
1		

Thanking You,

Yours faithfully,

Signature (Statutory Auditor/Cost Auditor/Practicing CA–As applicable)

Printed Name.....

Seal.....

UDIN No.....

Date.....

Place.....

BID for supply of 945 Numbers of Electric 2- Wheelers to Health Medical & Family Welfare Department, Mangalagiri, Guntur District

Format - X

Information on litigation history in which Tenderer is the Petitioner.

Sl. no	Case No/ year	Court where filed	Subject Matter / Prayer in the case	Respondents i.e., SE /CE	Present stage

Signature of the Tenderer

ANNEXURE - A: TECHNICAL SPECIFICATIONS OF ELECTRIC 2- WHEELERS

1. Motor Type : 3phase AC Induction Motor/BLDC HUB motor/PMS
2. Motor Capacity : 1.5kW and with 3 KW peak power
3. Battery Capacity : 60V/35 Ah
4. Range Per Charge : 80 KMPH and above
5. Maximum Speed : 55Kmph and above
6. Certification : ARAI/ICAT or any other designated labs under CMVR
7. GPS tracking system : Shall be provided
8. All wiring within the vehicle interior including boot space shall be concealed properly
9. Charging ports/points should be on the exterior body of the 2- Wheeler with a designated flap.
10. Charger as per ARAI/ICAT/DISCOM/CEA standards to be supplied along with the vehicle at no additional cost with guarantee for a period 5 years.
11. The E- 2Wheelers before delivery should meet all the regulatory and statutory norms and obtain all the approvals/NOCs from appropriate Indian Govt. type and model approval requirements by ARAI/ ICAT laboratories. In case the successful OEM (s) fails to comply with these requirements, order shall be canceled and shall be blacklisted for at least 3 years by NREDCAP from future tenders/EOIs.
12. The chassis of vehicle shall be guaranteed for a period of 5 years with metallic chassis protecting inner parts of the vehicle like battery, motor protecting inner parts of the vehicle like battery, motor and all other parts to suit rural areas.
13. The vehicle and battery shall be guaranteed for a period of 5 years or 50,000KMs whichever is earlier.

BID for supply of 945 Numbers of Electric 2- Wheelers to Health Medical & Family Welfare Department, Mangalagiri, Guntur District

ANNEXURE –B: SERVICE LEVEL AGREEMENT (SLA)

S. No.	Defined Parameter	Service Level Requirement	Validation Procedure	Proposed
1	Turnaround times for non-accidental repairs	<p>The turnaround time for non-accidental repairs should be no longer than 24 working hours from reporting of issue to nodal person designated by OEM to readiness for dispatch with the issues resolved in case of non-accidental repairs.</p> <p>All spares for repairs are to be maintained at a reasonable level to ensure adherence to turnaround times for repairs.</p>	<p>The successful OEM(s) shall maintain a record of</p> <ul style="list-style-type: none"> i. Intimation, in & out time of breakdown vehicle ii. OEM must maintain the record of breakdown issues and to submit the report on actions taken. <p>All the information sought in point (i), & (ii) to be submitted on monthly basis to the NREDCAP for certification by 7th of every calendar month.</p>	<p>Maximum turnaround time will be 48 working hours and will come under purview of OEM's Warranty Policy.</p> <p>The Start time will be considered from the time the vehicle is made available to the Dealership/ receipt of vehicle at dealership which should be before 10.30 am. In case of 1st year the OEM shall extend road side assistance and towing</p> <p>In case the vehicle is reported or received after 10.30 am, It will be considered as reported for next working day. Incase beyond 48 hours penalty of INR 100 per day per vehicle till the time of delivery.</p> <p>In case of same fault recurring in a particular vehicle more than 2 times with in a period of 2 months, penalty amounts as mentioned above will be doubled.</p> <p>Turn-around time is calculated from the time vehicle is reported to the workshop before 10:30am to the time work is completed and informed to customer to collect the vehicle from workshop by making any payment due. Any delay in approvals by customer for any request or intimation by the Workshop will not be calculated for Turn-around time calculation.</p> <p>In case of items covered and falls under the purview of Repair eg Battery, Support battery will be made available to customer on returnable basis wherein customer will return the Items provided under support within stipulated or defined time. Failure to do so will attract penalty of INR 100 per day payable by customer.</p>

BID for supply of 945 Numbers of Electric 2- Wheelers to Health Medical & Family Welfare Department, Mangalagiri, Guntur District

2	Turnaround times for accidental repairs	<p>In case of minor accident, the turnaround time should be no longer than 3 working days from approval from NREDCAP and /or insurance agency to readiness for dispatch with the issues resolved.</p> <p>In case of major accident, the turn-around time should be no longer than 10 working days from approval from NREDCAP and /or insurance agency to readiness for dispatch with the issues resolved.</p>	<p>OEM shall maintain a record of</p> <ul style="list-style-type: none"> i. Intimation, in & out time of breakdown vehicle ii. OEM has to maintain the record of breakdown issues and to submit the report on actions taken. <p>All the information sought in point (i) & (ii) to be submitted on monthly basis to the NREDCAP for certification by 7th of every calendar month.</p>	<p>For Minor Accident - 5 Working Days from the Time of Insurance claim clearance / Customer acceptance for Case were Insurance is not approved, must be received with advance payment. In case of more than 5 working days INR 100 per day per vehicle till the time vehicle is ready for delivery will be charged.</p> <p>For Major Accident - 12 Working Days from the Time of Insurance claim clearance / Customer acceptance for Case were Insurance is not approved, must be received with advance payment. In case of beyond 12 working days INR 100 per day per vehicle till the time vehicle is ready for delivery will be charged.</p> <p>Major accident relates to damage Tires are excluded from these terms.</p>
---	---	---	--	---

BID for supply of 945 Numbers of Electric 2- Wheelers to Health Medical & Family Welfare Department, Mangalagiri, Guntur District

ANNEXURE –C: DELIVERY DESTINATIONS

S.No	District	No of PHCs	945 Scooters with range 80KM	Delivery Destinations	Contact info
1	Srikakulam	83	54	O/o DM & HO, Srikakulam	Dr. B. Jagannadha Rao, DM&HO, Mob:9963994336
2	Vizianagaram	68	48	O/o DM & HO, Vizianagaram	Dr. SV.Ramana Kumar, DM&HO, Mob:9849902278
3	Visakhapatnam	88	52	O/o DM & HO, Visakhapatnam	Dr. K.Vijaya Lakshmi, DM&HO, Mob:9849902299
4	East Godavari	126	99	O/o DM & HO, East Godavari	Dr. B.Meenakshi, DM&HO, Mob:9849902301
5	West Godavari	92	77	O/o DM & HO, West Godavari	Dr. B.Ravi, DM&HO, Mob:9949623985
6	Krishna	88	83	O/o DM & HO, Krishna	Dr. M.Suhasini, DM&HO, Mob:9819902325
7	Guntur	86	80	O/o DM & HO, Guntur	Dr. Yasmin DM&HO, Mob: 9849902337
8	Prakasam	90	79	O/o DM & HO, Prakasam	Dr. P.Ratnavali DM&HO, Mob:9491044156
9	SPSR Nellore	75	70	O/o DM & HO, SPSR Nellore	Dr. S.Rajya Lakshmi, DM&HO, Mob:9849902361
10	Chittoor	101	91	O/o DM & HO, Chittoor	Dr. U.Srihari, DM&HO, Mob:9849902373
11	Kadapa	74	64	O/o DM & HO, Kadapa	Dr. K.Nagaraju DM&HO, Mob: 9849902385
12	Anantapur	87	76	O/o DM & HO, Anantapur	Dr.Y.Kameswara Prasad DM&HO, Mob: 9849902397
13	Kurnool	87	72	O/o DM & HO, Kurnool	Dr. B. Ramagiddaiah DM&HO, Mob: 9849902409
	Total	1145	945		

BID for supply of 945 Numbers of Electric 2- Wheelers to Health Medical & Family Welfare Department, Mangalagiri, Guntur District

ANNEXURE –D: PICTORIAL REPRESENTATION OF BOX

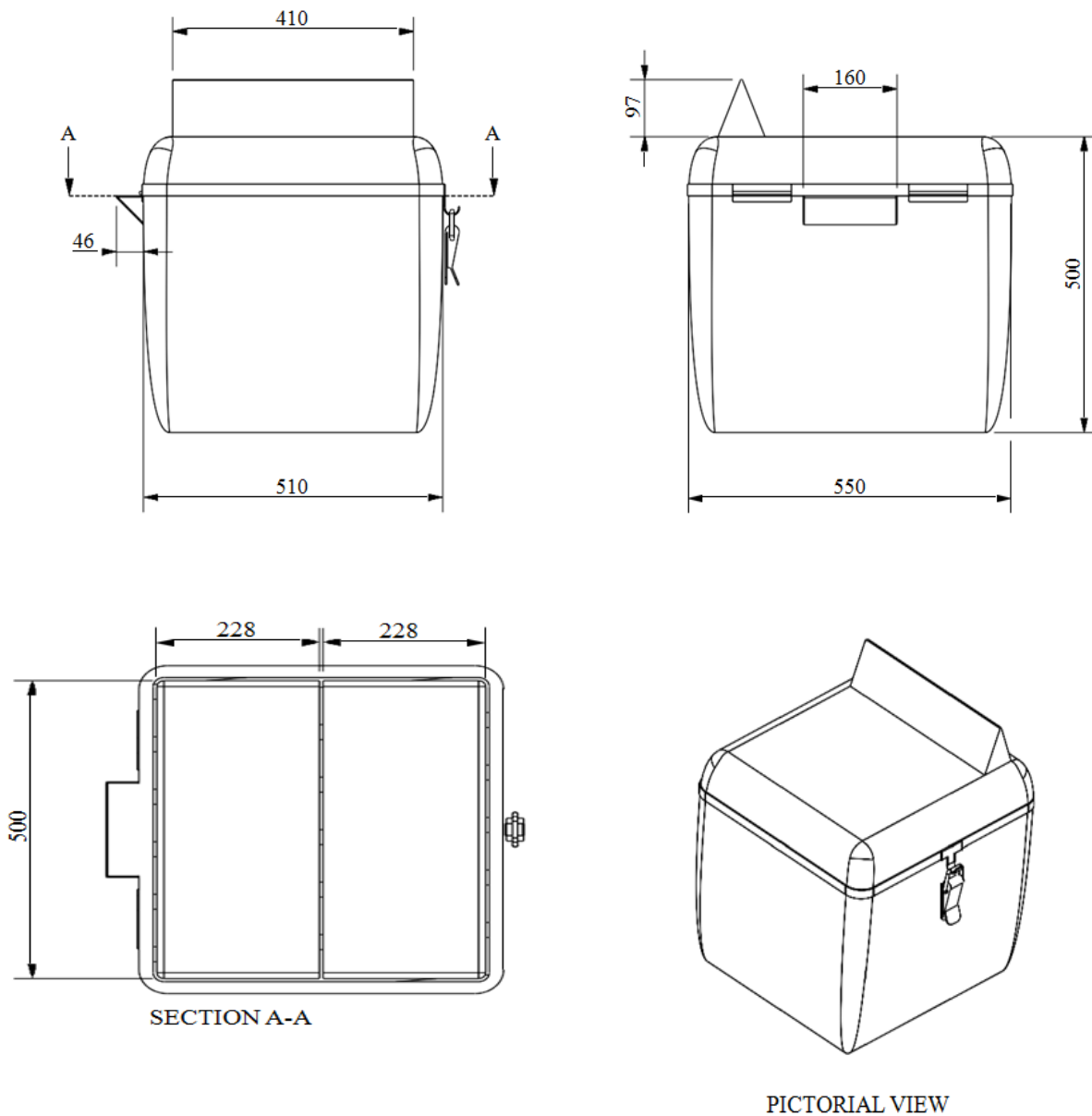

* All dimensions are in mm range for the above diagrams

Permissible Deviations as per ISO 2768-1

Scale: 0.200	Over	-	6	30	120	400	1000	2000
Dim Upto & incl		6	30	120	400	1000	2000	4000
Tolerance		±0.3	±0.5	±0.8	±1.2	±2.0	±3	±4

BID for supply of 945 Numbers of Electric 2- Wheelers to Health Medical & Family Welfare Department, Mangalagiri, Guntur District

CHECKLIST

S.No	Description	Submitted(Y/N)	Page No
A	B	C	D
1	General Details		
(a)	Name of the Applicant:		
(b)	Full address (Registered Office) with Phone/ Fax/ Email		
(c)	Head office (if different from Regd. Office) with Phone/ Fax/ Email details		
(d)	Name of the contact person with designation and Phone/ Fax/ Mobile No/ Email		
(e)	Type of the organization: (Public Sector/Limited/Private Limited Partnership/Proprietary /Society/Others.)		
(g)	Chief of the organization (s)		
(h)	Registration details like Registration certificate with MoCA and Memorandum of articles of association		
2	PAN No (Enclose copy of the certificates)		
3	Copy of GST Certificate		
4	Activities of the Company – Enclose Company profile/ Brochures, etc.,		
5	Bid Processing Fee of Rs.10,000 (plus GST) by way of Online to APTS Limited and Bid processing fee of Rs.1,00,000+ 18 % GST in favor of VC& Managing Director, NRDCAP		
6	Documentary Proof that they are in Electric Vehicles field for past 3 years.		
7	EMD for Rs25.00lakh in favor of VC & Managing Director, NREDCAP, Tadepalli by way of DD / Bank Guarantee in any Nationalized / Scheduled Banks.		
9	Details of accreditation certificates from designated labs for E- 2 Wheelers		
10	Copy of AP Transport Department approvals if any.		
11	Details of key personnel available		
12	The bidder should scan / furnish the detailed technical brochures, certifications etc., for the technology proposed to be adopted by him.		
13	<u>Proposed Technology:</u> Detailed methodology, proposed technology shall be provided.		
14	Any other information the applicant wants to furnish		
15	Format – I: prequalification check		
16	Format – II: Covering letter		
17	Format – III: Power of Attorney		
18	Format IV: Technical eligibility criteria		
19	Format V: Financial Eligibility criteria		
20	Format VI: Financial Bid		
21	Format VII: Bank Guarantee		
22	Format VIII: Declaration regarding ‘;Restriction on procurement from a Bidder of a country which shares a land border with India		
23	Format IX: Certificate regarding declaration of local content.		
24	Format: X: Litigation History		

Note: -

- a. All the pages of the document, enclosures shall be signed by the Bidder.